



Österreichisches Institut für Bautechnik
 Schenkenstrasse 4 | 1010 Vienna | Austria
 T +43 1 533 65 50 | F +43 1 533 64 23
 mail@oib.or.at | www.oib.or.at



European technical approval

ETA-13/0793

(English language translation, the original version is in German language)

Handelsbezeichnung
Trade name

BIS Pacifyre® EFC System

Zulassungsinhaber
Holder of approval

**J. van Walraven Holding B.V.
 Industrieweg 5
 3641 RK Mijdrecht
 THE NETHERLANDS**

Zulassungsgegenstand
 und Verwendungszweck

Rohrabschottung

*Generic type and use of
 construction product*

Pipe penetration seal

Geltungsdauer vom
Validity from
 bis
to

28.06.2013

27.06.2018

Herstellwerk
Manufacturing plant

Walraven Factory S2

Diese Europäische
 technische Zulassung umfasst
*This European
 technical approval contains*

68 Seiten inklusive 5 Anhänge

68 pages including 5 Annexes

I LEGAL BASES AND GENERAL CONDITIONS

- 1 This European technical approval is issued by the Österreichisches Institut für Bautechnik in accordance with:
- Council Directive 89/106/EEC of 21 December 1988 on the approximation of laws, regulations and administrative provisions of Member States relating to construction products¹, modified by the Council Directive 93/68/EEC² and Regulation (EC) no. 1882/2003 of the European Parliament and of the Council³;
 - Wiener Bauprodukte- und Akkreditierungsgesetz – WBAG. LGBl. Nr. 30/1996, zuletzt geändert durch das Gesetz LGBl. für Wien Nr. 8/2012;
 - Common Procedural Rules for Requesting, Preparing and the Granting of European technical approvals set out in the Annex to Commission Decision 94/23/EC⁴;
 - Guideline for European technical approval for “Fire Stopping and Fire Sealing Products – Part 2: Penetration Seals” ETAG no. 026-Part 2, edition August 2011.
- 2 The Österreichisches Institut für Bautechnik is authorised to check whether the provisions of this European technical approval are met. Checking may take place in the manufacturing plant. Nevertheless, the responsibility for the conformity of the products to the European technical approval and for their fitness for the intended use remains with the holder of the European technical approval.
- 3 This European technical approval is not to be transferred to manufacturers or agents of manufacturer other than those indicated on page 1, or manufacturing plants other than those laid down in the context of this European technical approval.
- 4 This European technical approval may be withdrawn by the Österreichisches Institut für Bautechnik, in particular pursuant to information by the Commission according to Article 5(1) of Council Directive 89/106/EEC.
- 5 Reproduction of this European technical approval including transmission by electronic means shall be in full. However, partial reproduction can be made with the written consent of the Österreichisches Institut für Bautechnik. In this case, partial reproduction has to be designated as such. Texts and drawings of advertising brochures shall not contradict or misuse the European technical approval.
- 6 The European technical approval is issued by the Approval Body in its official language. This version corresponds fully to the version circulated within EOTA. Translations into other languages have to be designated as such.

¹ Official Journal of the European Communities no. L 40, 11.2.1989, p. 12

² Official Journal of the European Communities no. L 220, 30.8.1993, p. 1

³ Official Journal of the European Union no. L 284, 31.10.2003, p. 1

⁴ Official Journal of the European Communities no. L 17, 20.1.1994, p. 34

II SPECIFIC CONDITIONS OF THE EUROPEAN TECHNICAL APPROVAL

1 Definition of Pipe penetration seal “BIS Pacifyre® EFC System” and intended use

The Pipe penetration seal “BIS Pacifyre® EFC System” is installed in accordance with the ETA-holder’s design and installation instructions, deposited at the Österreichisches Institut für Bautechnik. The Pipe penetration seal “BIS Pacifyre® EFC System” comprises the following components, which are factory-produced by the ETA-holder or a supplier. The ETA-holder is ultimately responsible for the Pipe penetration seal “BIS Pacifyre® EFC System”.

1.1 Definition of the construction product

“BIS Pacifyre® EFC System” is a pipe penetration seal based on the Pipe collar “BIS Pacifyre® EFC” and additional gap fillers and insulations.

Components of Pipe collar “BIS Pacifyre® EFC”	Characteristics
BIS Pacifyre® IM 2	Flexible intumescent strip (provided with a self-adhesive device) with a nominal thickness of 2,0 mm and a width of 40 mm
BIS Pacifyre® IM 3	Flexible intumescent strip (provided with a self-adhesive device) with a nominal thickness of 2,0 mm and a width of 40 mm
BIS Pacifyre® EFC Band	Metal strap according to Annex A-1 of the ETA made of sheet steel (alloy 1.4016 according to EN 10088-2) with a width of 42,5 mm for fixing of “BIS Pacifyre® IM 2” and “BIS Pacifyre® IM 3”
BIS Pacifyre® EFC Hook	Metal hook according to Annex A-1 of the ETA made of sheet steel (alloy 1.4016 according to EN 10088-2) for fixing the BIS Pacifyre® EFC Band to the separating element

Gap fillers (additional components)	Characteristics
BIS Pacifyre® FPF	Intumescent fire protection foam on the basis of polyurethane (2-component) – filled in cartridges – only to be used as gap filler in rigid floors for plastic pipes “Wavin SiTech®”, “Geberit Silent-PP”, “POLO-KAL NG” and “RAUPIANO PLUS”
Gap Filler	Non-combustible material with classification A1 or A2-s1,d0 according to EN 13501-1 which is dimensionally stable as e.g. mortar, cement or gypsum joint filler

electronic copy

Insulations (additional components)	Characteristics
AF/Armaflex or equal product	Closed cell, flexible elastomeric foam (FEF) insulation in form of (slotted) tubes (can be provided with a self-adhesive device) with classification B _L -s3,d0 – including “Armaflex Kleber 520” (Armaflex Adhesive 520) – according to EN 13501-1 from manufacturer “Armacell GmbH”
AF/Armaflex Band selbstklebend (AF/Armaflex self-adhesive tape) or equal product	Closed cell, flexible elastomeric foam (FEF) insulation in form of tapes with a self-adhesive device with classification B-s3,d0 according to EN 13501-1 from manufacturer “Armacell GmbH”
SH/Armaflex or equal product	Closed cell, flexible elastomeric foam (FEF) insulation in form of (slotted) tubes (can be provided with a self-adhesive device) with classification B _L -s3,d0 – including “Armaflex Kleber 520” (Armaflex Adhesive 520) – according to EN 13501-1 from manufacturer “Armacell GmbH”
SH/Armaflex Band selbstklebend (SH/Armaflex self-adhesive tape) or equal product	Closed cell, flexible elastomeric foam (FEF) insulation in form of tapes with a self-adhesive device with classification B-s3,d0 according to EN 13501-1 from manufacturer “Armacell GmbH”
Armaflex Kleber 520 (Armaflex Adhesive 520) or equal product	Polychlorene-based adhesive, free from aromatic compounds (special adhesive for processing of all flexible Armaflex insulating material – except “HT/Armaflex”) from manufacturer “Armacell GmbH”
Polyethylene sound insulation	Closed cell, flexible polyethylene foam insulation in form of tubes (can be faced with an inside and outside PE-foil) with a thickness of up to 4 mm, a density of 30 kg/m ³ to 40 kg/m ³ and classification E _L according to EN 13501-1 (e.g. THERMACOMPACT TF™ from manufacturer “thermaflex®”)

1.2 Intended use, use category and working life

1.2.1 Intended use

The Pipe penetration seal “BIS Pacifyre[®] EFC System” is intended to be used to temporarily or permanently reinstate the fire resistance performance of flexible wall constructions, rigid wall constructions and rigid floor constructions where they have been provided with apertures which are penetrated by various metal pipes and plastic pipes.

The Pipe penetration seal “BIS Pacifyre[®] EFC System” can be installed only in the types of separating elements as specified in the following table.

Separating element	Construction
Flexible walls	<ul style="list-style-type: none">> Steel studs or timber studs lined on both faces with minimum 2 layer of boards (minimum thickness 12,5 mm)> For timber stud walls there shall be a minimum distance of 100 mm of the penetration seal to any timber stud. The cavity between the penetration seal and the timber stud has to be closed with minimum 100 mm of insulation with classification A1 or A2 according to EN 13501-1> Minimum thickness 94 mm> Classification according to EN 13501-2: \geq EI 90> This European technical approval does not cover sandwich panel constructions and flexible walls where the lining does not cover studs on both sides. Penetrations in such constructions shall be tested on a case by case basis
Rigid walls	<ul style="list-style-type: none">> Aerated concrete, concrete, masonry> Minimum thickness 100 mm> The rigid wall shall be classified in accordance with EN 13501-2 for the required fire resistance period
Rigid floors	<ul style="list-style-type: none">> Aerated concrete, concrete> Minimum density 550 kg/m³> Minimum thickness 150 mm> The rigid floor shall be classified in accordance with EN 13501-2 for the required fire resistance period

The Pipe penetration seal “BIS Pacifyre® EFC System” can only be configured as specified in the following tables. Other parts or service support constructions shall not penetrate the penetration seal.

Penetrating element	Construction characteristics for installation of the penetrating element in flexible walls and rigid walls
Plastic pipes	<ul style="list-style-type: none"> > PVC-U pipes according to EN ISO 1452-1 or EN ISO 15493 and DIN 8061 / DIN 8062 with diameters and wall thicknesses as defined in Annex C-1 and Annex C-2 of the ETA. > PE-HD pipes according to EN 1519-1 or EN ISO 15494 and DIN 8074 / DIN 8075 with diameters and wall thicknesses as defined in Annex C-3 and Annex C-4 of the ETA. > PP pipes according to EN ISO 15494 and DIN 8077 / DIN 8078 with diameters and wall thicknesses as defined in Annex C-5 of the ETA. > “alpex F50 PROFI” and “alpex L” pipes from manufacturer “Fränkische Rohrwerke Gebr. Kirchner GmbH & Co. KG” or equal product with diameters and wall thicknesses as defined in Annex C-6 of the ETA. > “BluePower®” pipes from manufacturer “COES – Compagnia Edil Sanitaria S.p.A.” or equal product with diameters and wall thicknesses as defined in Annex C-7 of the ETA. > “Uponor Unipipe Mehrschichtverbundrohr MLC” pipes from manufacturer “Uponor GmbH” or equal product with diameters and wall thicknesses as defined in Annex C-8 of the ETA. > “Wavin SiTech®” pipes from manufacturer “Wavin GmbH” or equal product with diameters and wall thicknesses as defined in Annex C-9 of the ETA. > “Fusiotherm® Stabiverbundrohr” pipes from manufacturer “aquatherm GmbH” or equal product with diameters and wall thicknesses as defined in Annex C-10 of the ETA. > “Geberit Silent-PP” pipes from manufacturer “Geberit Vertriebs GmbH & Co KG” or equal product with diameters and wall thicknesses as defined in Annex C-11 of the ETA. > “POLO-KAL NG” pipes from manufacturer “POLOPLAST GmbH & Co KG” or equal product with diameters and wall thicknesses as defined in Annex C-12 of the ETA. > “RAUPIANO PLUS” pipes from manufacturer “REHAU AG & Co” or equal product with diameters and wall thicknesses as defined in Annex C-13 of the ETA. > “Triplus®” pipes from manufacturer “Valsir S.p.A. Sanitaria Idraulica Riscaldamento” or equal product with diameters and wall thicknesses as defined in Annex C-14 of the ETA.

electronic copy

Penetrating element	Construction characteristics for installation of the penetrating element in rigid floors
Plastic pipes	<ul style="list-style-type: none"> > “POLO-KAL NG” pipes from manufacturer “POLOPLAST GmbH & Co KG” or equal product with diameters and wall thicknesses as defined in Annex E-11 of the ETA. > “RAUPIANO PLUS” pipes from manufacturer “REHAU AG & Co” or equal product with diameters and wall thicknesses as defined in Annex E-12 of the ETA.
Metal pipes	<ul style="list-style-type: none"> > Metal pipes of reaction to fire class A1 according to EN 13501-1 with a melting or decomposition point greater or equal than copper (1085 °C) and a thermal conductivity smaller or equal than copper with diameters and wall thicknesses as defined in Annex E-13 and Annex E-14 of the ETA. > Metal pipes of reaction to fire class A1 according to EN 13501-1 with a melting or decomposition point greater or equal than steel (1085 °C) and a thermal conductivity smaller or equal than steel with diameters and wall thicknesses as defined in Annex E-13 and Annex E-14 of the ETA.

1.2.2 Use category

The Pipe penetration seal “BIS Pacifyre® EFC System” is intended for use at temperatures below 0 °C and with exposure to UV, but with no exposure to rain, and can therefore – according to ETAG 026-Part 2 clause 2.4.12.1.3.3 – be categorized as Type Y₁. Since the requirements for Type Y₁ are met, also the requirements for Type Y₂, Z₁ and Z₂ are fulfilled.

Although a penetration seal is intended for indoor applications only, the construction process may result in it being subjected to more exposed conditions for a period before the building envelope is closed. For this case provisions shall be made to protect temporarily exposed penetration seals according to the ETA-holder’s installation instructions.

1.2.3 Working life

The provisions made in this European technical approval are based on an assumed working life of the Pipe penetration seal “BIS Pacifyre® EFC System” of 10 years, provided the conditions laid down in clause 4 and 5 of the ETA relating to manufacturing, installation, use and repair are met.

The indications given on the intended working life cannot be interpreted as a guarantee given by the producer or the Approval Body, but are to be regarded only as a means for selecting the appropriate product in relation to the expected economically reasonable working life of the works.

The real working life might be, in normal use conditions, considerably longer without major degradation affecting the Essential Requirements.

2 Characteristics of the product and methods of verification

2.1 General

The identification tests and the assessment of the fitness for use according to the Essential Requirements were carried out in compliance with the “ETA Guideline no. 026-Part 2” concerning “Penetration Seals” –edition August 2011 (called ETAG 026-Part 2 in this ETA) and with the “EOTA Technical Report 024” concerning “Characterisation, Aspects of Durability and Factory Production Control for Reactive Materials, Components and Products” –edition November 2006, amended July 2009 (called TR 024 in this ETA).

Clause No.	ETA Clause No.	Characteristic	Test procedure / Evaluation
Mechanical resistance and stability			
	2.2	None	Not relevant
Safety in case of fire			
ETAG 2.4.1	2.3.1	Reaction to fire	Classification according to EN 13501-1
ETAG 2.4.2	2.3.2	Resistance to fire	Classification according to EN 13501-2:2007+A1:2009
Hygiene, health and environment			
ETAG 2.4.3	2.4.1	Air permeability (material property)	No Performance Determined
ETAG 2.4.4	2.4.2	Water permeability (material property)	No Performance Determined
ETAG 2.4.5	2.4.3	Release of dangerous substances	Declaration of manufacturer
Safety in use			
ETAG 2.4.6	2.5.1	Mechanical resistance and stability	No Performance Determined
ETAG 2.4.7	2.5.2	Resistance to impact / movement	No Performance Determined
ETAG 2.4.8	2.5.3	Adhesion	No Performance Determined
Protection against noise			
ETAG 2.4.9	2.6.1	Airborne sound insulation	No Performance Determined
Energy economy and heat retention			
ETAG 2.4.10	2.7.1	Thermal properties	No Performance Determined
ETAG 2.4.11	2.7.2	Water vapour permeability	No Performance Determined
General aspects relating to fitness for use			
ETAG 2.4.12	2.8	Exposure conditions	Test results of unexposed and exposed specimens

2.2 Mechanical resistance and stability

Not relevant.

2.3 Safety in case of fire

2.3.1 Reaction to fire

The components of Pipe penetration seal “BIS Pacifyre[®] EFC System” were assessed according to ETAG 026-Part 2 clause 2.4.1 and classified according to EN 13501-1.

Component	Class according to EN 13501-1
BIS Pacifyre [®] IM 2	E
BIS Pacifyre [®] IM 3	E
BIS Pacifyre [®] EFC Band	A1
BIS Pacifyre [®] EFC Hook	A1
BIS Pacifyre [®] FPF	E

The sheet steel of the “BIS Pacifyre[®] EFC Band” and the “BIS Pacifyre[®] EFC Hook” is classified Class A1 according to Commission Decision 96/603/EC⁵.

2.3.2 Resistance to fire

The Pipe penetration seal “BIS Pacifyre[®] EFC System” was tested according to ETAG 026-Part 2 clause 2.4.2 and EN 1366-3:2009 in conjunction with EN 1363-1:1999.

Based upon the gained test results and the field of application specified within EN 1366-3:2009 the Pipe penetration seal “BIS Pacifyre[®] EFC System” has been classified according to EN 13501-2:2007+A1:2009.

The fire resistance classes of the Pipe penetration seal “BIS Pacifyre[®] EFC System” in the relevant separating elements are listed in Annex C-1 to Annex C-15 and Annex E-1 to Annex E-14 of the ETA.

2.3.2.1 General

The Pipe penetration seal “BIS Pacifyre[®] EFC System” can be used for metal pipes and plastic pipes according to clause 1.2.1 of the ETA in apertures in walls (vertical separating element) and floors (horizontal separating element) according to clause 1.2.1 of the ETA.

Each metal pipe or plastic pipe which is to be sealed off has to be equipped separately with “BIS Pacifyre[®] EFC System”; except for multiple penetrations of maximum three plastic pipes (clearance between pipes maximum 15 mm; linear arrangement, no clusters) according to clause 1.2.1 of the ETA made from PVC-U, PE-HD or PP with diameters and wall thicknesses as defined in Annex C-15 and Annex E-13 of the ETA – these pipes can be equipped with one concerted Pipe collar “BIS Pacifyre[®] EFC”. For details see Annex B-5 and Annex D-8 of the ETA.

For plastic classified with pipe end configuration U/U the pipe end configuration can be U/U, C/U, U/C and C/C.

⁵ Official Journal of the European Communities no. L 267, 19.10.1996, p. 23

For plastic classified with pipe end configuration U/C the pipe end configuration can be U/C and C/C.

For metal classified with pipe end configuration C/U the pipe end configuration can be C/U and C/C.

Metal pipes and plastic pipes (except for some plastic pipes according to Annex C-1, Annex C-3, Annex C-5, Annex E-1, Annex E-2 and Annex E-4 of the ETA) have to be installed perpendicular to the surface of the separating element.

Some plastic pipes according to Annex C-1, Annex C-3, Annex C-5, Annex E-1, Annex E-2 and Annex E-4 of the ETA can be installed in all angles between 90° and 45°.

Metal pipes according to Annex C-15, Annex E-13 and Annex E-14 of the ETA have to be insulated with "AF/Armaflex".

Plastic pipes can be insulated with "AF/Armaflex", "SH/Armaflex" or Polyethylene sound insulation (e.g. "THERMACOMPACT TFTM") according to clause 1.1 of the ETA. In some cases it is mandatory to insulate the plastic pipes. For details see Annex C-1 to Annex C-15 and Annex E-1 to Annex E-13 of the ETA.

In case of multiple penetrations of maximum three plastic pipes (linear arrangement, no clusters) according to clause 1.2.1 of the ETA made from PVC-U, PE-HD or PP with diameters and wall thicknesses as defined in Annex C-15 and Annex E-13 of the ETA equipped with one concerted Pipe collar "BIS Pacifyre[®] EFC" which are installed in vertical separating elements the plastic pipes shall only be positioned in horizontal direction. For details see Annex B-5 and Annex D-8 of the ETA.

In some cases it is allowed to install the Pipe penetration seal "BIS Pacifyre[®] EFC System" on plastic pipes with bows on the bottom side of the floor and a connection sleeve within the floor. For details see Annex D-7, Annex E-8 and Annex E-10 to Annex E-12 of the ETA.

In some cases it is allowed for floor penetration to install the Pipe penetration seal "BIS Pacifyre[®] EFC System" on vertical plastic pipes which are positioned directly in the corner of the wall (clearance between pipe and wall maximum 10 mm). The Pipe collar "BIS Pacifyre[®] EFC" covers the pipe only from wall to wall. For details see Annex D-4, Annex D-5, Annex E-3, Annex E-4, Annex E-8 and Annex E-10 to Annex E-12 of the ETA.

All conduits / tubes, metal pipes and plastic pipes – in flexible walls and rigid walls – have to be supported on both side of the separating element by service support constructions (e.g. pipe hangers) made of metal with a melting or decomposition point greater or equal than 1085 °C (e.g. stainless steel or galvanized steel) according to the ETA-holder's installation instructions.

All conduits / tubes, metal pipes and plastic pipes – in rigid floors – have to be supported at least on the top side of the separating element by service support constructions (e.g. pipe hangers) made of metal with a decomposition point greater or equal than 1085 °C (e.g. stainless steel or galvanized steel) according to the ETA-holder's installation instructions.

The first support (service support construction) for metal pipes and plastic pipes in flexible walls and rigid walls has to be at maximum 650 mm (measured from the surface of the separating element).

The annular gap (maximum width 30 mm) between the penetrating elements (metal pipes and plastic pipes – including insulation) and the vertical separating element has to be completely filled with “Gap Filler” according to clause 1.1 of the ETA on both sides of the separating element.

The annular gap (maximum width 50 mm) between the penetrating elements (metal pipes and plastic pipes – including insulation) and the horizontal separating element has to be completely filled with “Gap Filler” according to clause 1.1 of the ETA on both sides of the separating element.

The annular gap (maximum width 30 mm) between plastic pipes (including insulation) “Wavin SiTech[®]”, “Geberit Silent-PP”, “POLO-KAL NG” or “RAUPIANO PLUS” and the horizontal separating element can be completely filled with “BIS Pacifyre[®] FPF” according to clause 1.1 of the ETA on both sides of the separating element.

The minimum clearance between two non-insulated pipes (linear arrangement, no clusters) is 100 mm (measured from the surface of the pipe).

The minimum clearance between two pipes (linear arrangement, no clusters) insulated with “AF/Armaflex”, “SH/Armaflex” or Polyethylene sound insulation (e.g. “THERMACOMPACT TFTM”) according to clause 1.1 of the ETA is 100 mm (measured from the surface of the insulation).

For multiple penetrations the minimum clearance between maximum three plastic pipes (linear arrangement, no clusters) according to clause 1.2.1 of the ETA made from PVC-U, PE-HD or PP with diameters and wall thicknesses as defined in Annex C-15 and Annex E-13 of the ETA equipped with one concerted Pipe collar “BIS Pacifyre[®] EFC” is 0 mm (measured from the surface of the pipe).

2.4 Hygiene, health and environment

2.4.1 Air permeability

No Performance Determined.

2.4.2 Water permeability

No Performance Determined.

2.4.3 Release of dangerous substances

According to the manufacturer’s declaration “BIS Pacifyre[®] IM 2” and “BIS Pacifyre[®] IM 3” and “BIS Pacifyre[®] FPF” do not contain dangerous substances detailed in Council Directive 67/548/EEC and Regulation (EC) no 1272/2008 above the acceptable limits.

A written declaration in this respect was submitted by the ETA-holder.

In addition to the specific clauses relating to dangerous substances contained in this European technical approval, there may be other requirements applicable to the products falling within its scope (e.g. transposed European legislation and national laws, regulations and administrative provisions). In order to meet the provisions of the Construction Product Directive, these requirements need also to be complied with, when and where they apply.

2.5 Safety in use

2.5.1 Mechanical resistance and stability

No Performance Determined.

2.5.2 Resistance to impact / movement

No Performance Determined.

2.5.3 Adhesion

No Performance Determined.

2.6 Protection against noise

2.6.1 Airborne sound insulation

No Performance Determined.

2.7 Energy economy and heat retention

2.7.1 Thermal properties

No Performance Determined.

2.7.2 Water vapour permeability

No Performance Determined.

2.8 General aspects relating to fitness for use

The components “BIS Pacifyre[®] EFC Band” and “BIS Pacifyre[®] EFC Hook” are made of ferritic stainless steel, material number 1.4016 according to EN 10088-2.

According to ETAG 026-Part 2 clause 2.4.12.1.2.5 and Annex B of EN 10088-1 ferritic stainless steels have relatively low corrosion resistance and their use should normally be restricted to mild indoor or similarly protected environments. This type of stainless steel is therefore suitable for use in use category Y₁.

The components “BIS Pacifyre[®] IM 2” and “BIS Pacifyre[®] IM 3” fulfil the requirements for use at conditions exposed to weathering and can – according to ETAG 026-Part 2 clause 2.4.12.1.3.3 – be categorized as Type X. Since the requirements for Type X are met, also the requirements for Type Y₁, Y₂, Z₁ and Z₂ are fulfilled.

The additional component “BIS Pacifyre[®] FPF” fulfils the requirements for use at conditions exposed to weathering and can – according to ETAG 026-Part 2 clause 2.4.12.1.3.3 – be categorized as Type X. Since the requirements for Type X are met, also the requirements for Type Y₁, Y₂, Z₁ and Z₂ are fulfilled.

All components of Pipe penetration seal “BIS Pacifyre[®] EFC System” fulfil the requirements for the intended use category.

The Pipe penetration seal “BIS Pacifyre[®] EFC System” is therefore appropriate for use at temperatures below 0 °C and with exposure to UV, but with no exposure to rain, and can – according to ETAG 026-Part 2 clause 2.4.12.1.3.3 – be categorized as Type Y₁. Since the requirements for Type Y₁ are met, also the requirements for Type Y₂, Z₁ and Z₂ are fulfilled.

The manufacturer may only use initial/raw/constituent materials stated in the technical documentation of this European technical approval.

For the components which the ETA-holder does not manufacture by himself, he shall make sure that factory production control carried out by the other manufacturers gives the guaranty of the components compliance with the European technical approval.

The factory production control and the provisions taken by the ETA-holder for components not produced by himself shall be in accordance with the control plan⁸ relating to this European technical approval, which is part of the technical documentation of this European technical approval. The control plan is laid down in the context of the factory production control system operated by the manufacturer and deposited at the Österreichisches Institut für Bautechnik.

The results of factory production control shall be recorded and evaluated in accordance with the provisions of the control plan.

3.2.1.2 Other tasks of the manufacturer

The manufacturer shall provide a technical data sheet and an installation instruction with the following minimum information:

- > Technical data sheet:
 - a) Field of application:
 - 1) Building elements for which the penetration seal is suitable, type and properties of the building elements like minimum thickness, density, and – in case of lightweight constructions – the construction requirements
 - 2) Services which may pass through the penetration seal, type and properties of the services like material, diameter, thickness etc. in case of pipes including insulation materials; necessary/allowed supports/fixings (e.g. pipe hangers)
 - 3) Limits in size, minimum thickness etc. of the penetration seal
 - 4) Environmental conditions covered by this European technical approval
 - b) Construction of the penetration seal including the necessary components and additional products (e.g. backfilling material) with clear indication whether they are generic or specific
- > Installation instruction:
 - a) Steps to be followed
 - b) Stipulations on maintenance, repair and replacement

The manufacturer shall, on the basis of a contract, involve a body (bodies) which is (are) notified for the tasks referred to in clause 3.1 of the ETA in the field of approval product in order to undertake the actions laid down in clause 3.3 of the ETA. For this purpose, the control plan referred to in clause 3.2.1.1 and 3.2.2 of the ETA shall be handed over by the manufacturer to the Notified Body or Bodies involved.

The manufacturer shall make a declaration of conformity, stating that the construction product is in conformity with the provisions of this European technical approval.

⁸ The control plan is a confidential part of the European technical approval and only handed over to the Notified Body or Bodies involved in the procedure of conformity.

3.2.2 Tasks of the Notified Bodies

The Notified Body (Bodies) shall perform the:

- > initial type-testing of the product
The results of the tests performed as part of the assessment for the European technical approval can be used unless there are changes in the production line or plant. In such cases, the necessary initial type testing has to be agreed between the Österreichisches Institut für Bautechnik and the Notified Bodies involved.
- > initial inspection of factory and of factory production control
The Notified Body (Bodies) shall ascertain that, in accordance with the control plan, the factory (in particular the employees and the equipment) and the factory production control are suitable to ensure continuous and orderly manufacturing of the components according to the specifications mentioned in clause 2 of the ETA.
- > continuous surveillance, assessment and approval of factory production control
The Notified Body (Bodies) shall visit the factory at least once a year for surveillance of this manufacturer having a FPC system complying with a quality management system covering the manufacturing of the approval product components. It has to be verified that the system of factory production control and the specified automated manufacturing process are maintained taking into account the control plan.

These tasks shall be performed in accordance with the provisions laid down in the control plan of this European technical approval.

The Notified Body (Bodies) shall retain the essential points of its (their) actions referred to above and state the results obtained and conclusions drawn in written report.

The Notified Body involved by the manufacturer shall issue an EC certificate of conformity of the product stating the conformity with the provisions of this European technical approval.

In cases where the provisions of the European technical approval and its control plan are no longer fulfilled, the Certification Body shall withdraw the certificate of conformity and inform the Österreichisches Institut für Bautechnik without delay.

3.3 CE marking

The CE marking of Pipe collar "BIS Pacifyre[®] EFC" shall be affixed on its packaging, as well as on the commercial documents accompanying the product. The CE marking of "BIS Pacifyre[®] FPF" shall be affixed on the product itself, as well as on its packaging and on the commercial documents accompanying the product. The letters "CE" shall be followed by the identification number of the Notified Body involved and be accompanied by the following additional information:

- > the name or identifying mark and address of the ETA-holder
- > the last two digits of the year in which the CE marking was affixed
- > the number of the EC certificate of conformity for the product
- > the number of the European technical approval
- > the number of the guideline for European technical approval (ETAG N° 026 part 2)
- > the name and intended use of the product
- > "see ETA-13/0793 for relevant characteristics"

4 Assumptions under which the fitness of the product for the intended use was favourably assessed

4.1 General

4.1.1 It is assumed that

- > damages to the penetration seal are repaired accordingly,
- > the installation of the penetration seal does not effect the stability of the adjacent building element – even in case of fire,
- > the thermal movement in the pipe work will be accommodated in such way that it does not impose a load on the penetration seal,
- > the installations are fixed to the adjacent building element in accordance with the relevant regulations in such a way that, in case of fire, no additional mechanical load is imposed to the penetration seal,
- > the support of the installations is maintained for the required period of fire resistance and
- > pneumatic dispatch systems, compressed air systems, etc. are switched off by additional means in case of fire (for sealing off plastic pipes).

4.1.2 This European technical approval does not address any risks associated with the emission of dangerous liquids or gases caused by failure of the pipe(s) in case of fire nor does it prove the prevention of the transmission of fire through heat transfer via the medium in the pipes.

4.1.3 This European technical approval does not verify the prevention of destruction of adjacent building elements with fire separating function or of the pipes themselves due to distortion forces caused by extreme temperatures. These risks shall be accounted for by taking appropriate measures when designing or installing the pipe work.
The mounting or hanging of the pipes or the layout of the pipe work shall be implemented in such a way that the pipes and the fire resistant building elements shall remain functional within a period of time which corresponds to the fire resistance period required.

4.1.4 The risk of downward spread of fire caused by burning material which drips through a pipe to floors below, is not considered in this European technical approval (see EN 1366-3:2009, clause 1).

4.1.5 The durability assessment does not take account of the possible effect on the penetration seal of substances permeating through the pipe walls.

4.1.6 The assessment does not cover the avoidance of destruction of the penetration seal or of the adjacent building element(s) by forces caused by temperature changes in case of fire. This has to be considered when designing the piping system.

4.2 Manufacturing

The European technical approval is issued for the product on the basis of agreed data/information, deposited with the Österreichisches Institut für Bautechnik, which identifies the product that has been assessed and judged. Changes to the product or production process, which could result in this deposited data/information being incorrect, should be notified to the Österreichisches Institut für Bautechnik before the changes are introduced. The Österreichisches Institut für Bautechnik will decide whether or not such changes affect the European technical approval and consequently the validity of the CE marking on the basis of the European technical approval and if so whether further assessment or alterations to the European technical approval, shall be necessary.

4.3 Installation

The product shall be installed and used as described in this European technical approval. Additional marking of the penetration seal shall be done in case of national requirements.

5 Indications to the manufacturers

5.1 Packaging, transport and storage

The indications of the manufacturer regarding packaging, transport and storage have to be followed.

In the accompanying document and/or on the packaging the manufacturer shall give information as to transport and storage.

At least the following shall be indicated:

- > minimum and maximum storing temperature
- > maximum duration of storage (only for BIS Pacifyre® FPF)
- > required data related to minimum temperature for transport and storage.

The packaging of the approval product shall at least contain the following information:

- > trade name or trademark or other symbol identifying the product
- > the date of manufacture (day, month, year or coded information)

The approval product shall be packaged for delivery in compliance with the usual delivery conditions and providing sufficient protection against the effects of normal handling.

5.2 Use, maintenance and repair

The fire resistance of the penetration seal shall not be negatively affected by future changes to buildings or building elements.

The assessment of the fitness for use is based on the assumption that necessary maintenance and repair if required is carried out in accordance with the manufacturer's instructions during the assumed intended working life.

On behalf of Österreichisches Institut für Bautechnik

The original document is signed by:

Rainer Mikulits
Managing Director

electronic copy
electronic copy
electronic copy
electronic copy
electronic copy
electronic copy

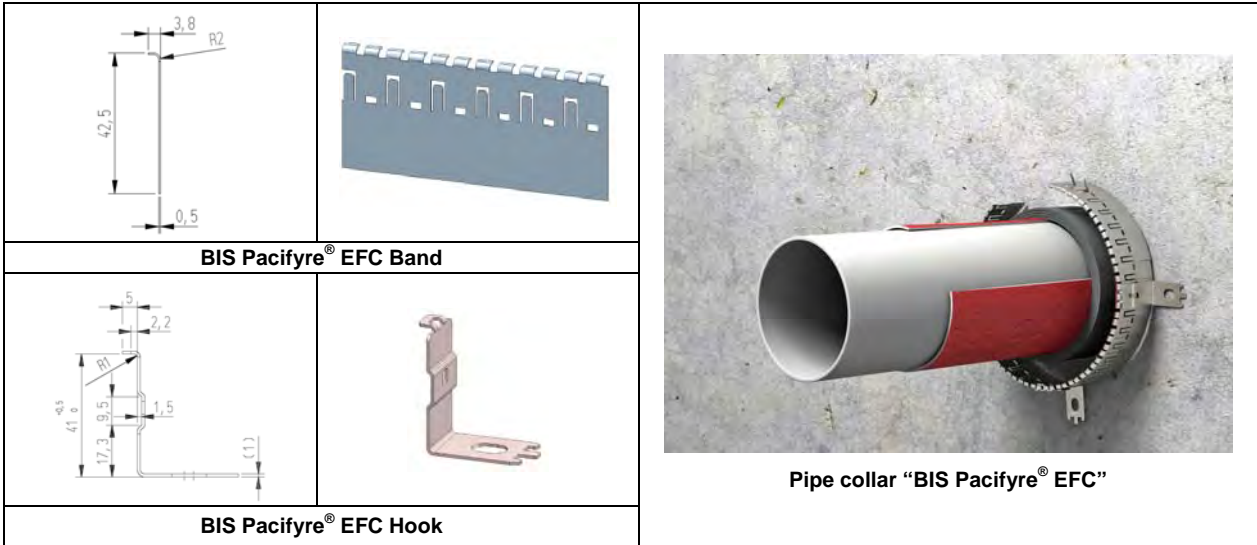

Separating element	Orientation	Pipe outer diameter (mm)	Minimum number of Hooks
Flexible wall	perpendicular	≤ 50	2
	perpendicular	> 50 to ≤ 110	3
	perpendicular	> 110 to ≤ 160	4
	angle between 90° and 45°	≤ 50	3
	angle between 90° and 45°	> 50 to ≤ 110	4
	angle between 90° and 45°	> 110 to ≤ 160	6
Rigid wall or Rigid floor	perpendicular	≤ 50	2
	perpendicular	> 50 to ≤ 110	3
	perpendicular	> 110	4
	angle between 90° and 45°	≤ 50	3
	angle between 90° and 45°	> 50 to ≤ 110	4
	angle between 90° and 45°	> 110 to ≤ 160	6

Installation of “BIS Pacifyre® EFC Band” – flexible wall acc. to cl. 1.2.1 of the ETA:

- > The “BIS Pacifyre® EFC Bands” have to be installed on both sides of the flexible wall.
- > The minimum number of “BIS Pacifyre® EFC Hooks” has to be taken from the table above.
- > The “BIS Pacifyre® EFC Hooks” shall be distributed equally around the pipe to be sealed off.
- > In case of multiple penetrations of maximum three plastic pipes (clearance between pipes maximum 15 mm; linear arrangement, no clusters) according to clause 1.2.1 of the ETA made from PVC-U, PE-HD or PP through one concerted Pipe collar “BIS Pacifyre® EFC” between each pipe one “BIS Pacifyre® EFC Hook” on the top side and the bottom side of the “BIS Pacifyre® EFC Band” has to be installed.
- > The “BIS Pacifyre® EFC Bands” have to be fixed by threaded steel bolts (outer diameter 6 mm to 8 mm – for pipes with outer diameter ≤ 50 mm or 8 mm – for pipes with outer diameter > 50 mm; length ≥ thickness of the separating element) and on both sides of the separating element with washers and nuts (corresponding to the outer diameter of the threaded steel bolts).

Installation of “BIS Pacifyre® EFC Band” – rigid wall or rigid floor acc. to cl. 1.2.1 of the ETA:

- > The “BIS Pacifyre® EFC Band” has to be installed on one side of the rigid wall or on the bottom side of the rigid floor.
- > The minimum number of “BIS Pacifyre® EFC Hooks” has to be taken from the table above.
- > The “BIS Pacifyre® EFC Hooks” shall be distributed equally around the pipe to be sealed off.
- > In case the “BIS Pacifyre® EFC Band” is installed on a vertical plastic pipe which is positioned directly in the corner of the wall (clearance between pipe and wall maximum 10 mm) three “BIS Pacifyre® EFC Hooks” have to be used (one “BIS Pacifyre® EFC Hook” in each corner and one in the middle of the “BIS Pacifyre® EFC Band”).
- > In case of multiple penetrations of maximum three plastic pipes (clearance between pipes maximum 15 mm; linear arrangement, no clusters) according to clause 1.2.1 of the ETA made from PVC-U, PE-HD or PP through one concerted Pipe collar “BIS Pacifyre® EFC” between each pipe one “BIS Pacifyre® EFC Hook” on the top side and the bottom side of the “BIS Pacifyre® EFC Band” has to be installed.
- > The “BIS Pacifyre® EFC Band” has to be fixed by appropriate steel dowels resp. steel screw anchors (outer diameter ≥ 6 mm) and washers (corresponding to the outer diameter of the steel dowels resp. steel screw anchors). In case of aerated concrete the “BIS Pacifyre® EFC Band” can alternatively be fixed by steel dry-wall screws (outer diameter ≥ 5 mm; length ≥ 50 mm) and washers (corresponding to the outer diameter of the steel dry-wall screws).

**Pipe penetration seal
“BIS Pacifyre® EFC System”
- Description and details for installation -**

ANNEX A-1

electronic copy electronic copy electronic copy electronic copy electronic copy electronic copy electronic copy electronic copy electronic copy electronic copy

Installation of “AF/Armaflex” or “SH/Armaflex”:

- > The thickness of the tube has to correspond with the provisions given in Annex C-1 to Annex C-15 and Annex E-1 to Annex E-14 of the ETA.
- > The length of the tube has to be ≥ 500 mm (local-sustained LS or continued-sustained CS) on both sides of the separating element (measured from the surface of the separating element).
- > The tube has to be continuous along the required minimum insulation length.
- > When installing the tubes all butt joints and longitudinal joints (except for tubes with self-adhesive device) have to be glued with “Armaflex Kleber 520” (Armaflex Adhesive 520) and can be covered with “AF/Armaflex Band selbstklebend” (AF/Armaflex self-adhesive tape) or “SH/Armaflex Band selbstklebend” (SH/Armaflex self-adhesive tape).
- > The amount of “Armaflex Kleber 520” (Armaflex Adhesive 520) shall not be more than given in the technical literature of the manufacturer.
- > The strip of “AF/Armaflex Band selbstklebend” (AF/Armaflex self-adhesive tape) or “SH/Armaflex Band selbstklebend” (SH/Armaflex self-adhesive tape) have to be 50 mm x 3 mm (width x thickness).
- > Branches or elbows also have to be equipped with tubes along the required minimum insulation length (≥ 500 mm – measured from the surface of the separating element) on both sides of the separating element.
- > For further details see technical literature of the manufacturer.

Installation of Polyethylene sound insulation (e.g. THERMACOMPACT TF™) acc. to cl. 1.1 of the ETA:

- > The tubes can either be pushed onto the pipe or slotted and wrapped around the pipe.
- > The pipes can be insulated in the penetration area exclusively (flushed within the penetration seal) as well as at their complete length.
- > As the dimensions of the tubes are given, the excess insulation material can be partially (on width between 20 mm to 40 mm) folded over the other at one point so that the thickness becomes 12 mm.
- > For further details see technical literature of the manufacturer.

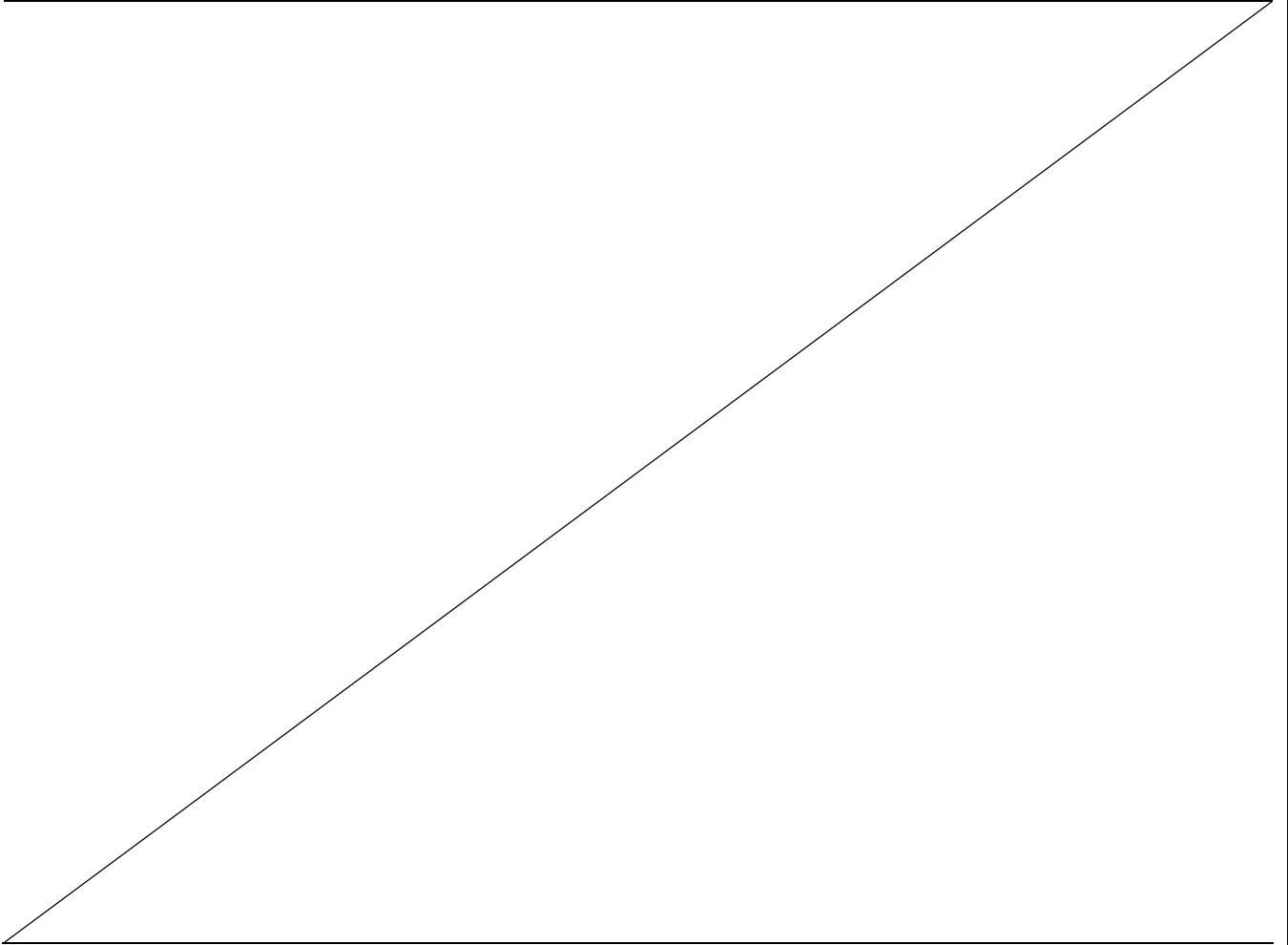

**Pipe penetration seal
“BIS Pacifyre® EFC System”
- Details for installation -**

ANNEX A-2

BIS Pacifyre® EFC System – flexible walls and rigid walls according to clause 1.2.1 of the ETA – plastic pipes according to clause 1.2.1 of the ETA, non-insulated – Installation drawing – sectional view

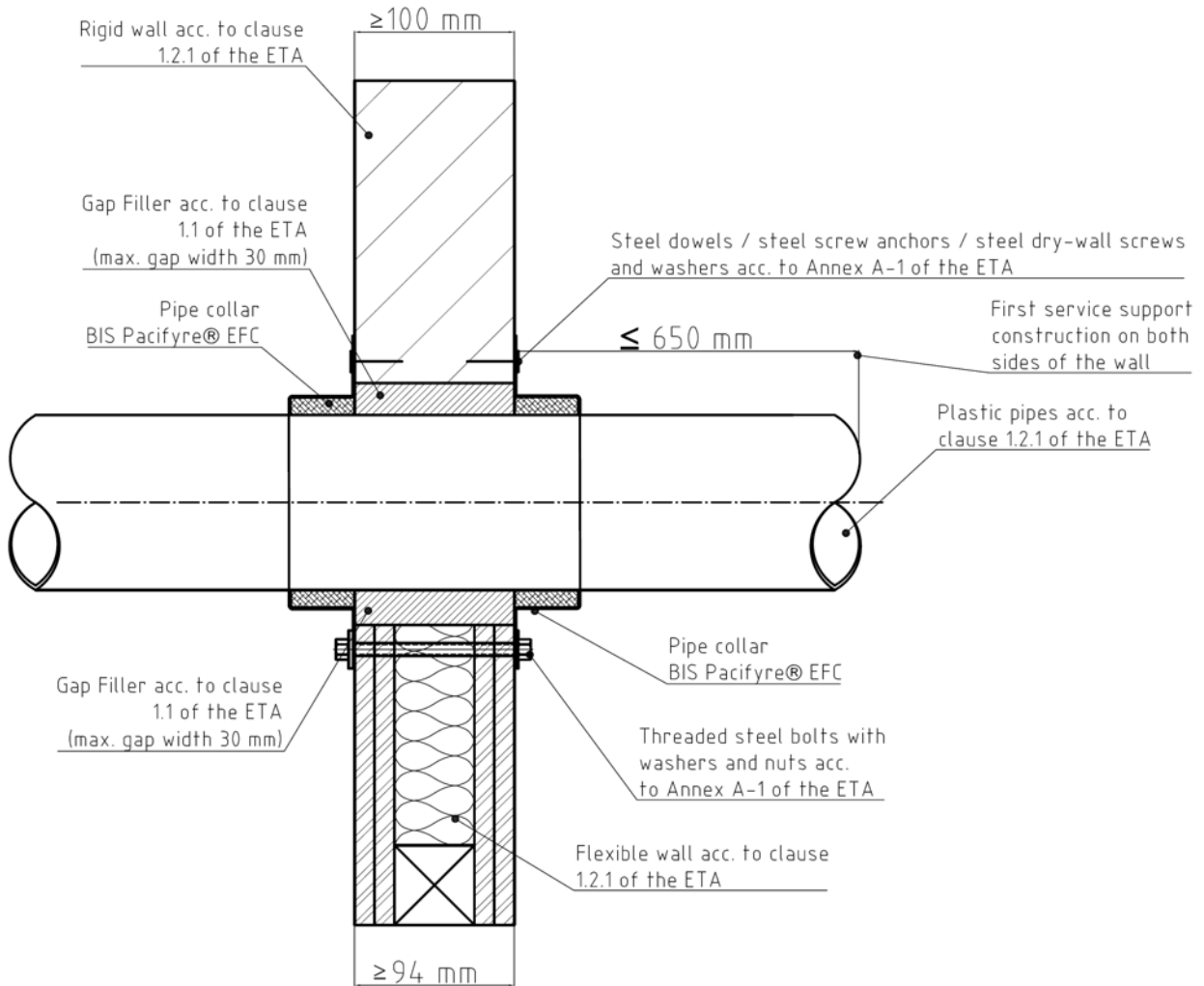

Pipe penetration seal
“BIS Pacifyre® EFC System”
- Installation in flexible wall and rigid wall -

ANNEX B-1

BIS Pacifyre® EFC System – flexible walls and rigid walls according to clause 1.2.1 of the ETA – plastic pipes according to clause 1.2.1 of the ETA, non-insulated, installed in an angle between 90° and 45° – Installation drawing – sectional view

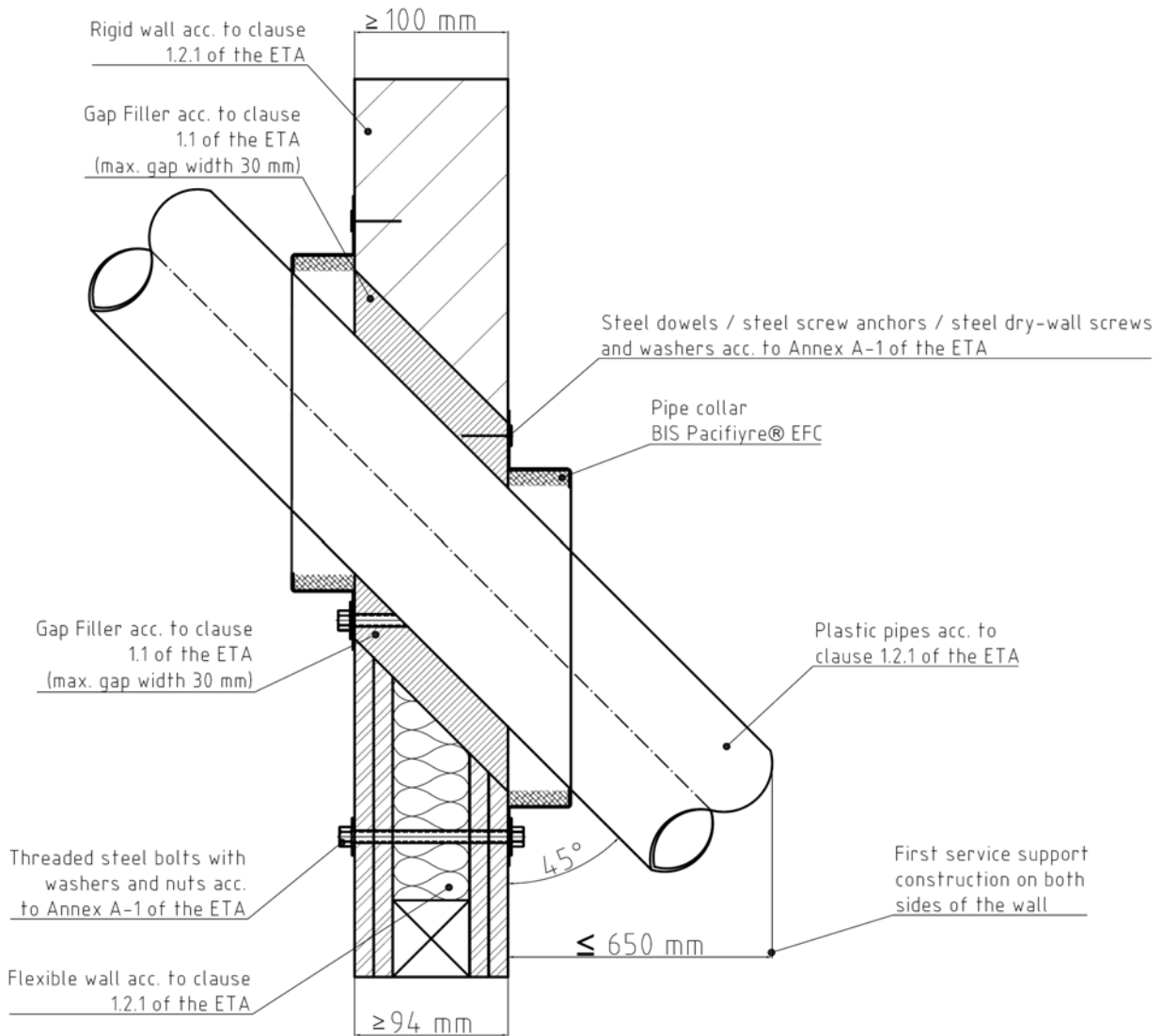

Pipe penetration seal
“BIS Pacifyre® EFC System”
- Installation in flexible wall and rigid wall -

ANNEX B-2

electronic copy electronic copy electronic copy electronic copy electronic copy electronic copy electronic copy electronic copy electronic copy electronic copy

BIS Pacifyre® EFC System – flexible walls and rigid walls according to clause 1.2.1 of the ETA – plastic pipes according to clause 1.2.1 of the ETA, insulated with Polyethylene sound insulation (e.g. THERMACOMPACT TF™) acc. to cl. 1.1 of the ETA – Installation drawing – sectional view

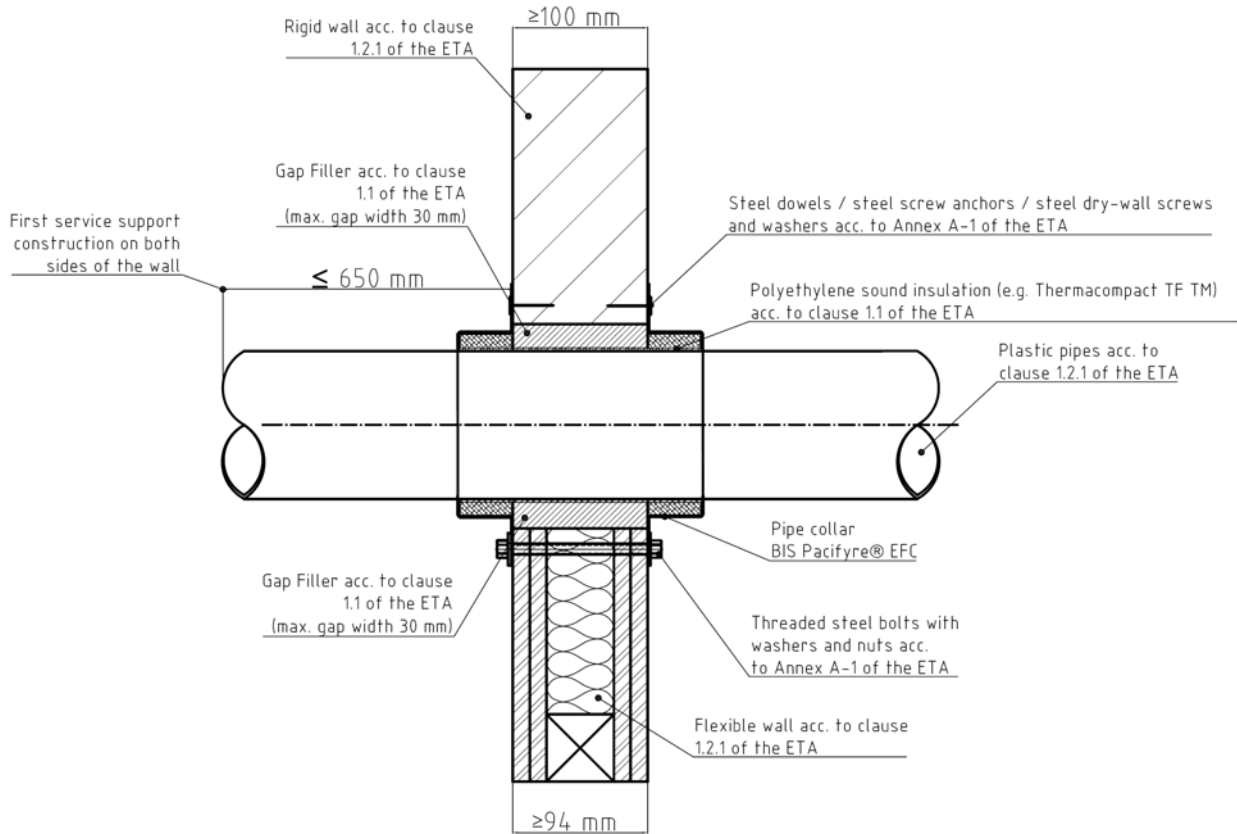

**Pipe penetration seal
“BIS Pacifyre® EFC System”
- Installation in flexible wall and rigid wall -**

ANNEX B-3

BIS Pacifyre® EFC System – flexible walls and rigid walls according to clause 1.2.1 of the ETA – plastic pipes according to clause 1.2.1 of the ETA, insulated with SH/Armaflex or AF/Armaflex – Installation drawing – sectional view

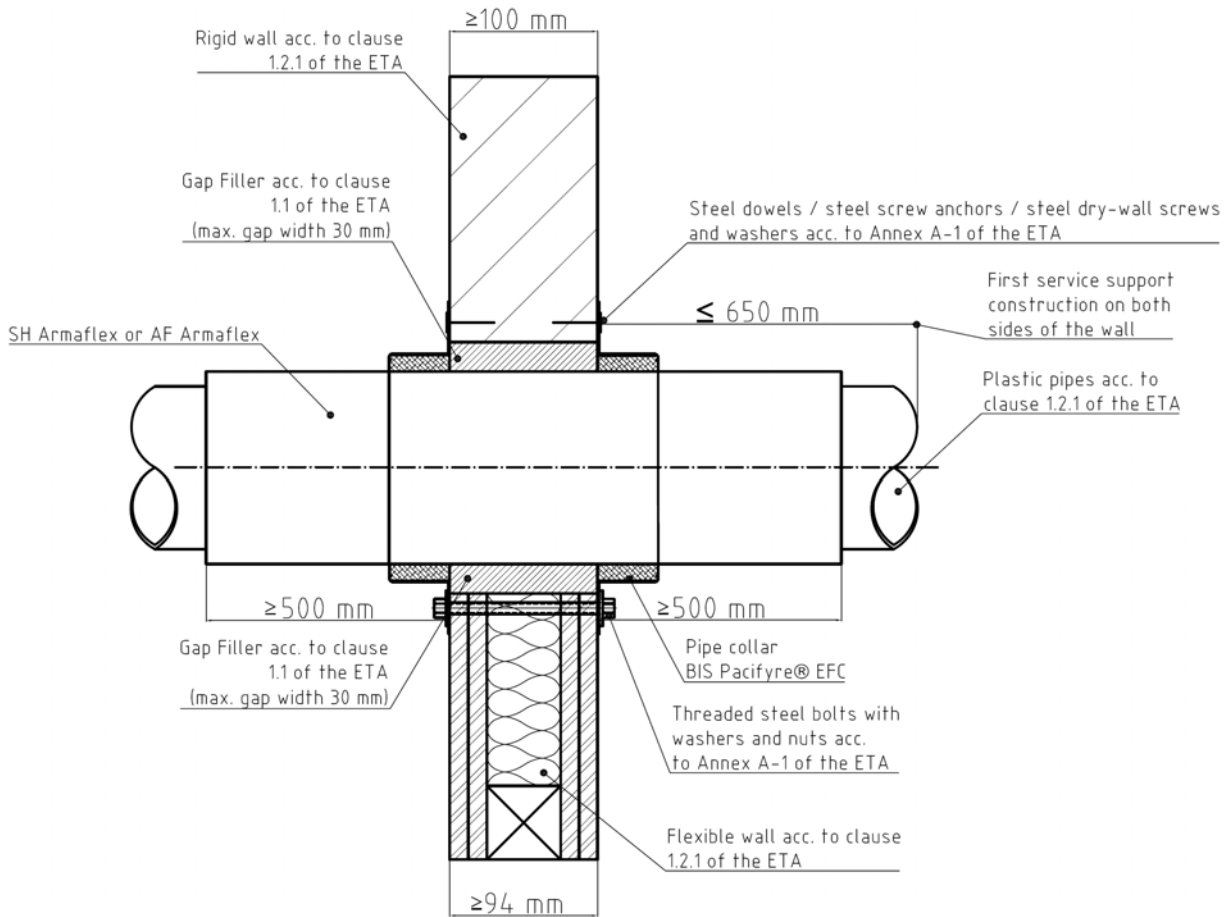

Pipe penetration seal
“BIS Pacifyre® EFC System”
- Installation in flexible wall and rigid wall -

ANNEX B-4

electronic copy electronic copy electronic copy electronic copy electronic copy electronic copy electronic copy electronic copy electronic copy electronic copy

BIS Pacifyre® EFC System – flexible walls and rigid walls according to clause 1.2.1 of the ETA – Multiple penetration of maximum three plastic pipes acc. to cl. 1.2.1 of the ETA made from PVC-U, PE-HD or PP through one concerted Pipe collar BIS Pacifyre® EFC (clearance between pipes maximum 15 mm; linear arrangement, no clusters), non-insulated – Installation drawing – top view

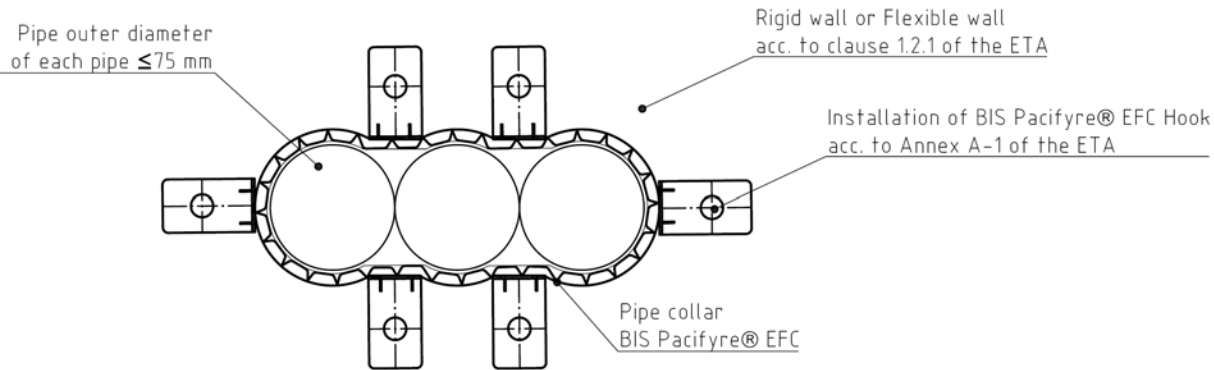

<p align="center"> Pipe penetration seal “BIS Pacifyre® EFC System” - Installation in flexible wall and rigid wall - </p>	<p align="center"> ANNEX B-5 </p>
--	--

BIS Pacifyre® EFC System – flexible walls and rigid walls according to clause 1.2.1 of the ETA – metal pipes according to clause 1.2.1 of the ETA, insulated with AF/Armaflex – intumescent inlays on both sides flushed within the separating element (without BIS Pacifyre® EFC Band) – Installation drawing – sectional view

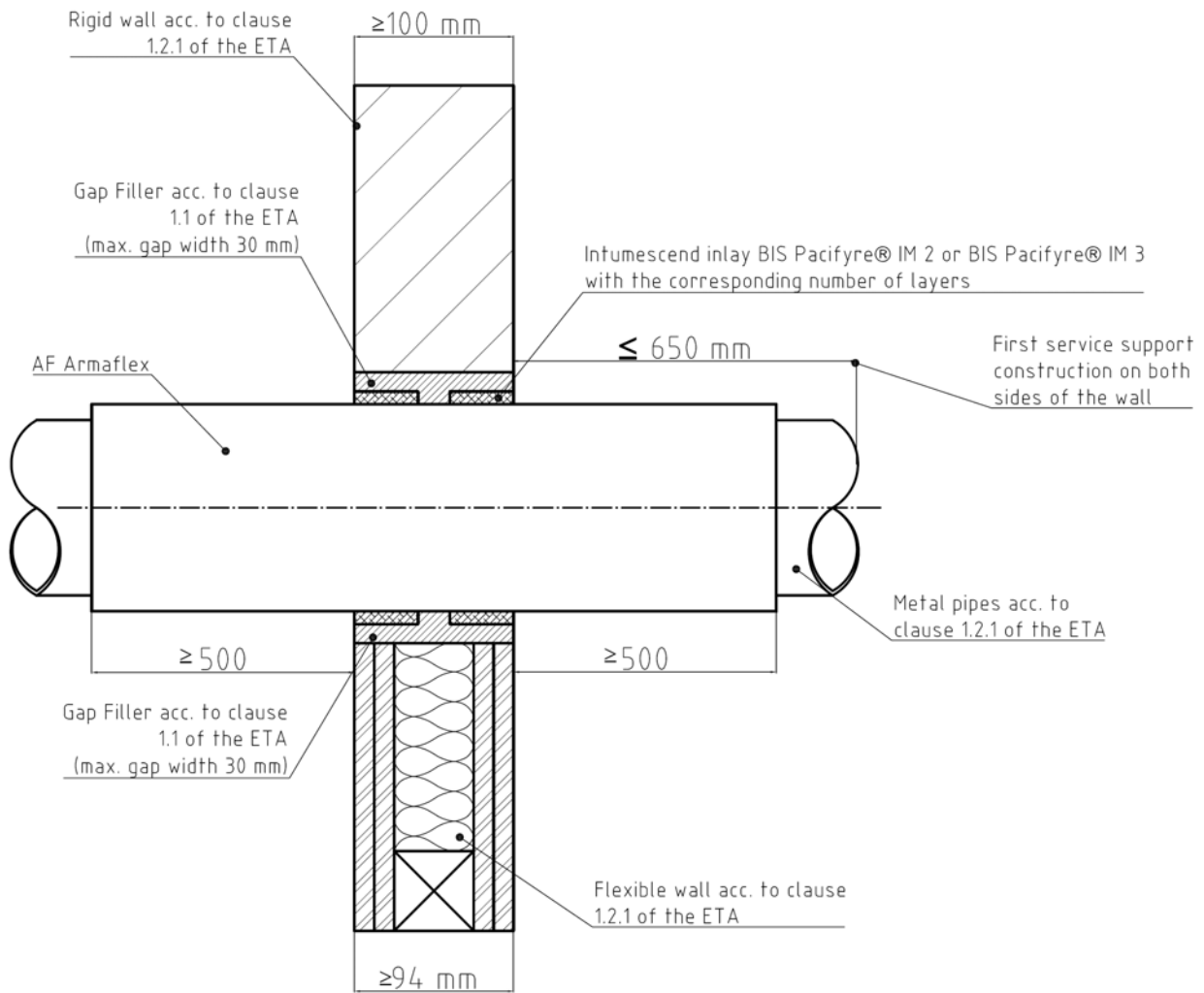

Pipe penetration seal
“BIS Pacifyre® EFC System”
- Installation in flexible wall and rigid wall -

ANNEX B-6

BIS Pacifyre® EFC System – flexible walls and rigid walls according to clause 1.2.1 of the ETA – metal pipes according to clause 1.2.1 of the ETA insulated with AF/Armaflex and an additional layer of AF/Armaflex – intumescent inlays on both sides flushed within the separating element (without BIS Pacifyre® EFC Band) – Installation drawing – sectional view

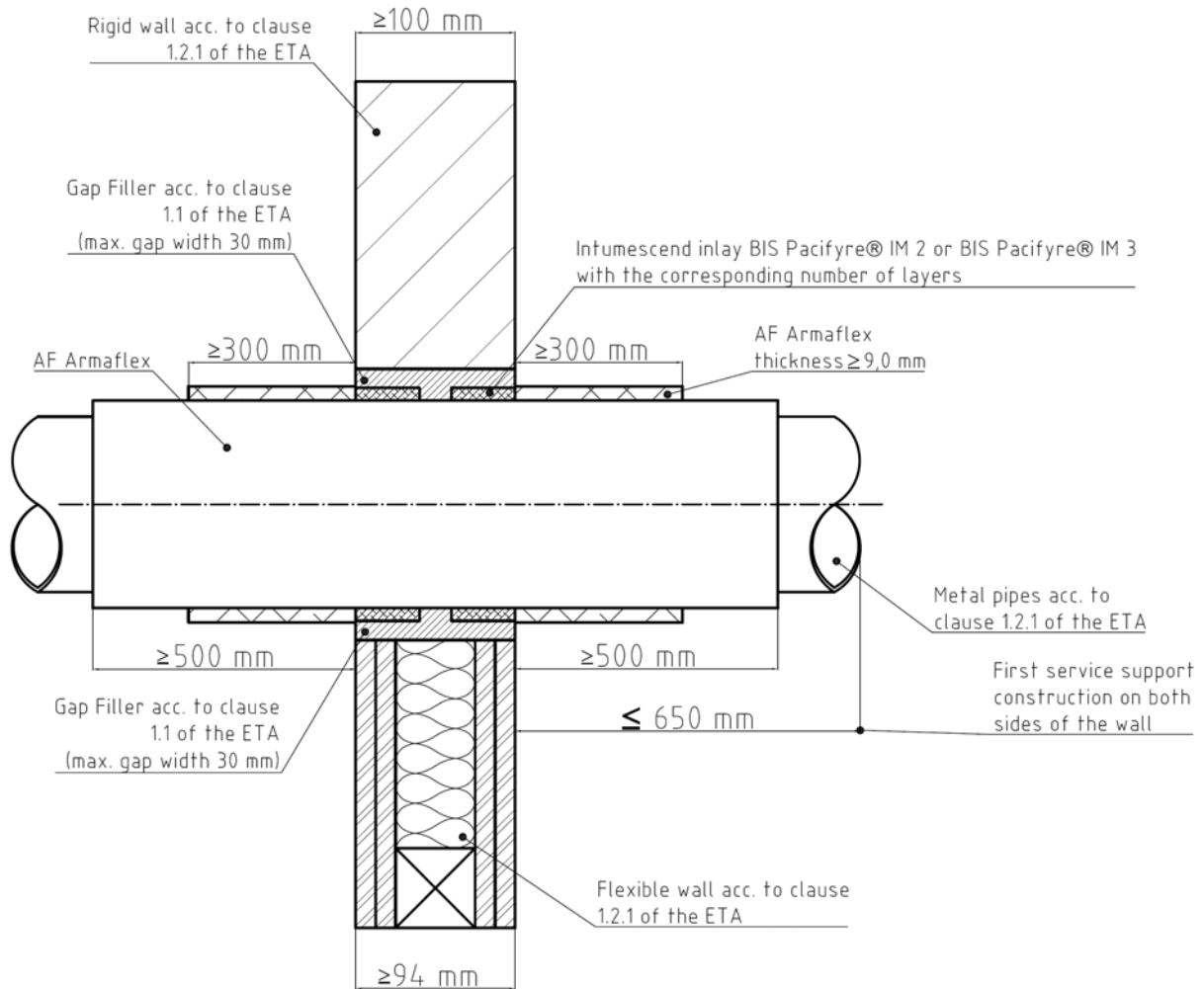

Pipe penetration seal
“BIS Pacifyre® EFC System”
- Installation in flexible wall and rigid wall -

ANNEX B-7

PVC-U pipes acc. to cl. 1.2.1 of the ETA, non-insulated – in flexible walls and rigid walls acc. to cl. 1.2.1 of the ETA						
Pipe dimensions (mm)		Insulation thickness (mm)	Intumescent inlay			Fire resistance classification
Outer diameter	Wall thickness		BIS Pacifyre® IM 3	BIS Pacifyre® IM 2	Nr. of layers	
≤ 50	1,8 to 5,6	---	X	X	2	EI 120-U/C E 120-U/C
> 50 to ≤ 75	1,8 to 8,4	---	X	X	3	EI 120-U/C E 120-U/C
> 75 to ≤ 110	1,8 to 12,3	---	X	X	4	EI 120-U/C E 120-U/C
> 110 to ≤ 125	2,2 to 12,2	---	X	X	5	EI 120-U/C E 120-U/C
> 125 to ≤ 160	3,2 to 11,9	---	X	X	6	EI 120-U/C E 120-U/C

PVC-U pipes acc. to cl. 1.2.1 of the ETA, non-insulated, installed in an angle between 90° and 45° – in flexible walls and rigid walls acc. to cl. 1.2.1 of the ETA						
Pipe dimensions (mm)		Insulation thickness (mm)	Intumescent inlay			Fire resistance classification
Outer diameter	Wall thickness		BIS Pacifyre® IM 3	BIS Pacifyre® IM 2	Nr. of layers	
≤ 50	1,8 to 5,6	---	X	X	2	EI 120-U/C E 120-U/C
> 50 to ≤ 75	1,8 to 8,4	---	X	X	3	EI 120-U/C E 120-U/C
> 75 to ≤ 110	1,8 to 12,3	---	X	X	4	EI 120-U/C E 120-U/C
> 110 to ≤ 125	2,2 to 12,2	---	X	X	6	EI 120-U/C E 120-U/C
> 125 to ≤ 160	3,2 to 11,9	---	X	X	8	EI 90-U/C E 90-U/C

--- ... no insulation allowed
X ... valid intumescent inlay

Pipe penetration seal “BIS Pacifyre® EFC System” - Fire resistance classification -	ANNEX C-1
--	------------------

PVC-U pipes acc. to cl. 1.2.1 of the ETA, insulated with Polyethylene sound insulation (e.g. THERMACOMPACT TF™) acc. to cl. 1.1 of the ETA – in flexible walls and rigid walls acc. to cl. 1.2.1 of the ETA

Pipe dimensions (mm)		Insulation thickness (mm)	Intumescent inlay			Fire resistance classification
Outer diameter	Wall thickness		BIS Pacifyre® IM 3	BIS Pacifyre® IM 2	Nr. of layers	
≤ 50	1,8	≤ 4	X	X	4	EI 90-U/C E 120-U/C
> 50 to ≤ 75	1,8	≤ 4	X	X	5	EI 90-U/C E 120-U/C
> 75 to ≤ 110	1,8	≤ 4	X	X	4	EI 90-U/C E 120-U/C
> 110 to ≤ 125	1,8 to 2,2	≤ 4	X	X	6	EI 90-U/C E 120-U/C
≤ 50	1,8 to 5,6	≤ 4	---	X	2	EI 120-U/U E 120-U/U
> 50 to ≤ 75	1,8 to 8,4	≤ 4	---	X	3	EI 90-U/U E 120-U/U
> 75 to ≤ 110	1,8 to 11,9	≤ 4	---	X	4	EI 90-U/U E 120-U/U
> 110 to ≤ 125	3,2 to 11,9	≤ 4	---	X	5	EI 90-U/U E 120-U/U
> 125 to ≤ 160	3,2 to 11,9	≤ 4	---	X	6	EI 120-U/U E 120-U/U

--- ... invalid intumescent inlay
X ... valid intumescent inlay

Pipe penetration seal
“BIS Pacifyre® EFC System”
- Fire resistance classification -

ANNEX C-2

electronic copy electronic copy electronic copy electronic copy electronic copy electronic copy electronic copy electronic copy electronic copy electronic copy

PE-HD pipes acc. to cl. 1.2.1 of the ETA, non-insulated – in flexible walls and rigid walls acc. to cl. 1.2.1 of the ETA						
Pipe dimensions (mm)		Insulation thickness (mm)	Intumescent inlay			Fire resistance classification
Outer diameter	Wall thickness		BIS Pacifyre® IM 3	BIS Pacifyre® IM 2	Nr. of layers	
≤ 50	1,8 to 4,6	---	X	X	2	EI 120-U/C E 120-U/C
> 50 to ≤ 75	1,8 to 8,4	---	X	X	3	EI 120-U/C E 120-U/C
> 75 to ≤ 110	2,7 to 10,0	---	X	X	4	EI 120-U/C E 120-U/C
> 110 to ≤ 160	4,0	---	X	X	8	EI 120-U/C E 120-U/C
> 110 to ≤ 160	> 4,0 to 14,6	---	X	X	8	EI 60-U/C E 60-U/C

PE-HD pipes acc. to cl. 1.2.1 of the ETA, non-insulated, installed in an angle between 90° and 45° – in flexible walls and rigid walls acc. to cl. 1.2.1 of the ETA						
Pipe dimensions (mm)		Insulation thickness (mm)	Intumescent inlay			Fire resistance classification
Outer diameter	Wall thickness		BIS Pacifyre® IM 3	BIS Pacifyre® IM 2	Nr. of layers	
≤ 50	1,8	---	X	X	2	EI 120-U/C E 120-U/C
> 50 to ≤ 75	1,8	---	X	X	4	EI 90-U/C E 90-U/C
> 75 to ≤ 110	2,7	---	X	X	5	EI 90-U/C E 90-U/C
> 110 to ≤ 125	3,2	---	X	X	7	EI 90-U/C E 90-U/C
> 125 to ≤ 160	4,0	---	X	X	8	EI 90-U/C E 90-U/C

--- ... no insulation allowed
X ... valid intumescent inlay

Pipe penetration seal “BIS Pacifyre® EFC System” - Fire resistance classification -	ANNEX C-3
--	------------------

PE-HD pipes acc. to cl. 1.2.1 of the ETA, insulated with Polyethylene sound insulation (e.g. THERMACOMPACT TF™) acc. to cl. 1.1 of the ETA – in flexible walls and rigid walls acc. to cl. 1.2.1 of the ETA

Pipe dimensions (mm)		Insulation thickness (mm)	Intumescent inlay			Fire resistance classification
Outer diameter	Wall thickness		BIS Pacifyre® IM 3	BIS Pacifyre® IM 2	Nr. of layers	
≤ 50	1,8 to 4,6	≤ 4	X	X	2	EI 120-U/C E 120-U/C
> 50 to ≤ 75	1,8 to 6,8	≤ 4	X	X	3	EI 120-U/C E 120-U/C
> 75 to ≤ 110	1,8 to 10,0	≤ 4	X	X	4	EI 120-U/C E 120-U/C
> 110 to ≤ 160	4,0	≤ 4	X	X	6	EI 120-U/C E 120-U/C
> 110 to ≤ 160	> 4,0 to 14,6	≤ 4	X	X	6	EI 90-U/C E 120-U/C
≤ 50	1,8 to 4,6	≤ 4	---	X	2	EI 120-U/U E 120-U/U
> 50 to ≤ 75	2,7	≤ 4	---	X	3	EI 120-U/U E 120-U/U
> 75 to ≤ 110	2,7	≤ 4	---	X	4	EI 120-U/U E 120-U/U

--- ... invalid intumescent inlay
X ... valid intumescent inlay

Pipe penetration seal
“BIS Pacifyre® EFC System”
- Fire resistance classification -

ANNEX C-4

PP pipes acc. to cl. 1.2.1 of the ETA, non-insulated – in flexible walls and rigid walls acc. to cl. 1.2.1 of the ETA						
Pipe dimensions (mm)		Insulation thickness (mm)	Intumescent inlay			Fire resistance classification
Outer diameter	Wall thickness		BIS Pacifyre® IM 3	BIS Pacifyre® IM 2	Nr. of layers	
≤ 50	1,8 to 4,6	---	X	X	2	EI 120-U/C E 120-U/C
> 50 to ≤ 75	1,8 to 8,4	---	X	X	3	EI 120-U/C E 120-U/C
> 75 to ≤ 110	2,7 to 10,0	---	X	X	4	EI 120-U/C E 120-U/C
> 110 to ≤ 160	4,0	---	X	X	8	EI 90-U/C E 120-U/C
> 110 to ≤ 160	> 4,0 to 14,6	---	X	X	6	EI 90-U/C E 90-U/C

PP pipes acc. to cl. 1.2.1 of the ETA, non-insulated, installed in an angle between 90° and 45° – in flexible walls and rigid walls acc. to cl. 1.2.1 of the ETA						
Pipe dimensions (mm)		Insulation thickness (mm)	Intumescent inlay			Fire resistance classification
Outer diameter	Wall thickness		BIS Pacifyre® IM 3	BIS Pacifyre® IM 2	Nr. of layers	
≤ 50	1,8	---	X	X	2	EI 120-U/C E 120-U/C
> 50 to ≤ 75	1,8	---	X	X	3	EI 120-U/C E 120-U/C
> 75 to ≤ 110	2,7	---	X	X	4	EI 120-U/C E 120-U/C

--- ... no insulation allowed
X ... valid intumescent inlay

PP pipes acc. to cl. 1.2.1 of the ETA, insulated with Polyethylene sound insulation (e.g. THERMACOMPACT TF™) acc. to cl. 1.1 of the ETA – in flexible walls and rigid walls acc. to cl. 1.2.1 of the ETA						
Pipe dimensions (mm)		Insulation thickness (mm)	Intumescent inlay			Fire resistance classification
Outer diameter	Wall thickness		BIS Pacifyre® IM 3	BIS Pacifyre® IM 2	Nr. of layers	
≤ 50	1,8 to 4,6	≤ 4	---	X	2	EI 120-U/U E 120-U/U
> 50 to ≤ 75	1,8 to 2,7	≤ 4	---	X	3	EI 120-U/U E 120-U/U
> 75 to ≤ 110	2,7	≤ 4	---	X	4	EI 120-U/U E 120-U/U

--- ... invalid intumescent inlay
X ... valid intumescent inlay

Pipe penetration seal
“BIS Pacifyre® EFC System”
- Fire resistance classification -

ANNEX C-5

electronic copy electronic copy electronic copy electronic copy electronic copy electronic copy electronic copy electronic copy electronic copy electronic copy

Plastic pipes alpex F50 PROFI acc. to cl. 1.2.1 of the ETA, non-insulated – in flexible walls and rigid walls acc. to cl. 1.2.1 of the ETA						
Pipe dimensions (mm)		Insulation thickness (mm)	Intumescent inlay			Fire resistance classification
Outer diameter	Wall thickness		BIS Pacifyre® IM 3	BIS Pacifyre® IM 2	Nr. of layers	
≤ 16	2,0	---	X	X	2	EI 120-U/C E 120-U/C

--- ... no insulation allowed
X ... valid intumescent inlay

Plastic pipes alpex F50 PROFI and alpex L acc. to cl. 1.2.1 of the ETA, insulated with SH/Armaflex (length ≥ 500 mm – on both sides of the separating element, local-sustained LS or continued- sustained CS) – in flexible walls and rigid walls acc. to cl. 1.2.1 of the ETA						
Pipe dimensions (mm)		Insulation thickness (mm)	Intumescent inlay			Fire resistance classification
Outer diameter	Wall thickness		BIS Pacifyre® IM 3	BIS Pacifyre® IM 2	Nr. of layers	
≤ 16	2,0	9,0	X	X	2	EI 120-U/C E 120-U/C
≤ 50	4,0	10,0	X	X	3	EI 60-U/C E 120-U/C
≤ 75	5,0	9,0	X	X	4	EI 90-U/C E 120-U/C
≤ 75	5,0	> 9,0 to 20,0	X	X	5	EI 90-U/C E 90-U/C
≤ 75	5,0	> 20,0 to 30,0	X	X	6	EI 90-U/C E 90-U/C
≤ 75	5,0	> 30,0 to 44,0	X	X	6	EI 90-U/C E 120-U/C

Plastic pipes alpex F50 PROFI and alpex L acc. to cl. 1.2.1 of the ETA, insulated with AF/Armaflex (length ≥ 500 mm – on both sides of the separating element, local-sustained LS or continued- sustained CS) – in flexible walls and rigid walls acc. to cl. 1.2.1 of the ETA						
Pipe dimensions (mm)		Insulation thickness (mm)	Intumescent inlay			Fire resistance classification
Outer diameter	Wall thickness		BIS Pacifyre® IM 3	BIS Pacifyre® IM 2	Nr. of layers	
≤ 75	5,0	9,5	X	X	4	EI 120-U/C E 120-U/C
≤ 75	5,0	> 9,5 to 20,0	X	X	5	EI 120-U/C E 120-U/C
≤ 75	5,0	> 20,0 to 30,0	X	X	6	EI 120-U/C E 120-U/C

X ... valid intumescent inlay

Pipe penetration seal “BIS Pacifyre® EFC System” - Fire resistance classification -	ANNEX C-6
--	------------------

electronic copy electronic copy electronic copy electronic copy electronic copy electronic copy electronic copy electronic copy

Plastic pipes BluePower [®] acc. to cl. 1.2.1 of the ETA, insulated with Polyethylene sound insulation (e.g. THERMACOMPACT TF TM) acc. to cl. 1.1 of the ETA – in flexible walls and rigid walls acc. to cl. 1.2.1 of the ETA						
Pipe dimensions (mm)		Insulation thickness (mm)	Intumescent inlay			Fire resistance classification
Outer diameter	Wall thickness		BIS Pacifyre [®] IM 3	BIS Pacifyre [®] IM 2	Nr. of layers	
≤ 50	1,8	≤ 4	X	X	2	EI 120-U/C E 120-U/C
≤ 75	2,5	≤ 4	X	X	3	EI 120-U/C E 120-U/C
≤ 110	3,4	≤ 4	X	X	4	EI 120-U/C E 120-U/C

X ... valid intumescent inlay

Pipe penetration seal
“BIS Pacifyre[®] EFC System”
- Fire resistance classification -

ANNEX C-7

electronic copy electronic copy electronic copy electronic copy electronic copy electronic copy electronic copy electronic copy electronic copy electronic copy

Plastic pipes Uponor Unipipe Mehrschichtverbundrohr MLC acc. to cl. 1.2.1 of the ETA, non-insulated – in flexible walls and rigid walls acc. to cl. 1.2.1 of the ETA						
Pipe dimensions (mm)		Insulation thickness (mm)	Intumescent inlay			Fire resistance classification
Outer diameter	Wall thickness		BIS Pacifyre® IM 3	BIS Pacifyre® IM 2	Nr. of layers	
≤ 16	2,0	---	X	X	2	EI 120-U/C E 120-U/C

--- ... no insulation allowed
X ... valid intumescent inlay

Plastic pipes Uponor Unipipe Mehrschichtverbundrohr MLC acc. to cl. 1.2.1 of the ETA, insulated with SH/Armaflex (length ≥ 500 mm – on both sides of the separating element, local-sustained LS or continued-sustained CS) – in flexible walls and rigid walls acc. to cl. 1.2.1 of the ETA						
Pipe dimensions (mm)		Insulation thickness (mm)	Intumescent inlay			Fire resistance classification
Outer diameter	Wall thickness		BIS Pacifyre® IM 3	BIS Pacifyre® IM 2	Nr. of layers	
≤ 16	2,0	9,0	X	X	2	EI 120-U/C E 120-U/C
≤ 50	4,5	10,0	X	X	3	EI 60-U/C E 120-U/C
≤ 110	10,0	9,0	X	X	6	EI 120-U/C E 120-U/C
≤ 110	10,0	> 9,0 to 20,0	X	X	6	EI 90-U/C E 120-U/C

Plastic pipes Uponor Unipipe Mehrschichtverbundrohr MLC acc. to cl. 1.2.1 of the ETA, insulated with AF/Armaflex (length ≥ 500 mm – on both sides of the separating element, local-sustained LS or continued-sustained CS) – in flexible walls and rigid walls acc. to cl. 1.2.1 of the ETA						
Pipe dimensions (mm)		Insulation thickness (mm)	Intumescent inlay			Fire resistance classification
Outer diameter	Wall thickness		BIS Pacifyre® IM 3	BIS Pacifyre® IM 2	Nr. of layers	
≤ 50	4,5	27,5	X	X	4	EI 120-U/C E 120-U/C
≤ 110	10,0	9,5	X	X	6	EI 120-U/C E 120-U/C
≤ 110	10,0	19,0	X	X	6	EI 90-U/C E 120-U/C
≤ 110	10,0	30,0	X	X	6	EI 120-U/C E 120-U/C

X ... valid intumescent inlay

Pipe penetration seal “BIS Pacifyre® EFC System” - Fire resistance classification -	ANNEX C-8
--	------------------

electronic copy electronic copy electronic copy electronic copy electronic copy electronic copy electronic copy electronic copy electronic copy electronic copy

Plastic pipes Wavin SiTech [®] acc. to cl. 1.2.1 of the ETA, insulated with Polyethylene sound insulation (e.g. THERMACOMPACT TF TM) acc. to cl. 1.1 of the ETA – in flexible walls and rigid walls acc. to cl. 1.2.1 of the ETA						
Pipe dimensions (mm)		Insulation thickness (mm)	Intumescent inlay			Fire resistance classification
Outer diameter	Wall thickness		BIS Pacifyre [®] IM 3	BIS Pacifyre [®] IM 2	Nr. of layers	
≤ 50	2,0	≤ 4	X	X	2	EI 120-U/C E 120-U/C
≤ 110	3,6	≤ 4	X	X	4	EI 90-U/C E 120-U/C
≤ 110	3,6	≤ 4	X	X	5	EI 120-U/C E 120-U/C
≤ 160	5,3	≤ 4	X	X	8	EI 120-U/C E 120-U/C
≤ 50	2,0	≤ 4	---	X	2	EI 120-U/U E 120-U/U
≤ 75	2,6	≤ 4	---	X	3	EI 120-U/U E 120-U/U
≤ 110	3,6	≤ 4	---	X	4	EI 120-U/U E 120-U/U

--- ... invalid intumescent inlay
X ... valid intumescent inlay

Pipe penetration seal “BIS Pacifyre[®] EFC System” - Fire resistance classification -	ANNEX C-9
---	------------------

Plastic pipes Fusiotherm® Stabverbundrohr acc. to cl. 1.2.1 of the ETA, non-insulated – in flexible walls and rigid walls acc. to cl. 1.2.1 of the ETA						
Pipe dimensions (mm)		Insulation thickness (mm)	Intumescent inlay			Fire resistance classification
Outer diameter	Wall thickness		BIS Pacifyre® IM 3	BIS Pacifyre® IM 2	Nr. of layers	
≤ 16	2,2	---	X	X	2	EI 120-U/C E 120-U/C
≤ 50	6,9	---	X	X	2	EI 120-U/C E 120-U/C
≤ 75	6,9	---	X	X	3	EI 120-U/C E 120-U/C
≤ 110	15,2	---	X	X	4	EI 120-U/C E 120-U/C

--- ... no insulation allowed
X ... valid intumescent inlay

Plastic pipes Fusiotherm® Stabverbundrohr acc. to cl. 1.2.1 of the ETA, insulated with SH/Armaflex (length ≥ 500 mm – on both sides of the separating element, local-sustained LS or continued-sustained CS) – in flexible walls and rigid walls acc. to cl. 1.2.1 of the ETA						
Pipe dimensions (mm)		Insulation thickness (mm)	Intumescent inlay			Fire resistance classification
Outer diameter	Wall thickness		BIS Pacifyre® IM 3	BIS Pacifyre® IM 2	Nr. of layers	
≤ 16	2,2	9,0	X	X	3	EI 120-U/C E 120-U/C
≤ 50	6,9	10,0	X	X	3	EI 120-U/C E 120-U/C

Plastic pipes Fusiotherm® Stabverbundrohr acc. to cl. 1.2.1 of the ETA, insulated with AF/Armaflex (length ≥ 500 mm – on both sides of the separating element, local-sustained LS or continued-sustained CS) – in flexible walls and rigid walls acc. to cl. 1.2.1 of the ETA						
Pipe dimensions (mm)		Insulation thickness (mm)	Intumescent inlay			Fire resistance classification
Outer diameter	Wall thickness		BIS Pacifyre IM 3	BIS Pacifyre IM 2	Nr. of layers	
≤ 110	15,2	31,0	X	X	6	EI 120-U/C E 120-U/C

X ... valid intumescent inlay

Pipe penetration seal “BIS Pacifyre® EFC System” - Fire resistance classification -	ANNEX C-10
--	-------------------

electronic copy electronic copy electronic copy electronic copy electronic copy electronic copy electronic copy electronic copy electronic copy electronic copy

Plastic pipes Geberit Silent-PP acc. to cl. 1.2.1 of the ETA, insulated with Polyethylene sound insulation (e.g. THERMACOMPACT TF™) acc. to cl. 1.1 of the ETA – in flexible walls and rigid walls acc. to cl. 1.2.1 of the ETA						
Pipe dimensions (mm)		Insulation thickness (mm)	Intumescent inlay			Fire resistance classification
Outer diameter	Wall thickness		BIS Pacifyre® IM 3	BIS Pacifyre® IM 2	Nr. of layers	
≤ 50	2,0	≤ 4	X	X	2	EI 120-U/C E 120-U/C
≤ 75	2,6	≤ 4	X	X	3	EI 90-U/C E 120-U/C
≤ 75	2,6	≤ 4	X	X	4	EI 120-U/C E 120-U/C
≤ 110	3,6	≤ 4	X	X	4	EI 90-U/C E 120-U/C
≤ 110	3,6	≤ 4	X	X	5	EI 120-U/C E 120-U/C
≤ 125	4,2	≤ 4	X	X	6	EI 120-U/C E 120-U/C
≤ 160	5,2	≤ 4	X	X	8	EI 120-U/C E 120-U/C
≤ 50	2,0	≤ 4	---	X	2	EI 120-U/U E 120-U/U
≤ 75	2,6	≤ 4	---	X	3	EI 120-U/U E 120-U/U
≤ 110	3,6	≤ 4	---	X	4	EI 120-U/U E 120-U/U
≤ 125	4,2	≤ 4	---	X	5	EI 120-U/U E 120-U/U
≤ 160	5,2	≤ 4	---	X	6	EI 120-U/U E 120-U/U

--- ... invalid intumescent inlay
X ... valid intumescent inlay

Pipe penetration seal “BIS Pacifyre® EFC System” - Fire resistance classification -	ANNEX C-11
--	-------------------

Plastic pipes POLO-KAL NG acc. to cl. 1.2.1 of the ETA, insulated with Polyethylene sound insulation (e.g. THERMACOMPACT TF™) acc. to cl. 1.1 of the ETA – in flexible walls and rigid walls acc. to cl. 1.2.1 of the ETA						
Pipe dimensions (mm)		Insulation thickness (mm)	Intumescent inlay			Fire resistance classification
Outer diameter	Wall thickness		BIS Pacifyre® IM 3	BIS Pacifyre® IM 2	Nr. of layers	
≤ 50	2,0	≤ 4	X	X	2	EI 120-U/C E 120-U/C
≤ 75	2,6	≤ 4	X	X	3	EI 90-U/C E 120-U/C
≤ 110	3,4	≤ 4	X	X	4	EI 90-U/C E 120-U/C
≤ 110	3,4	≤ 4	X	X	5	EI 120-U/C E 120-U/C
≤ 125	3,9	≤ 4	X	X	5	EI 120-U/C E 120-U/C
≤ 160	4,9	≤ 4	X	X	6	EI 120-U/C E 120-U/C
≤ 50	2,0	≤ 4	---	X	2	EI 120-U/U E 120-U/U
≤ 75	2,6	≤ 4	---	X	3	EI 120-U/U E 120-U/U
≤ 110	3,4	≤ 4	---	X	4	EI 120-U/U E 120-U/U
≤ 125	3,9	≤ 4	---	X	5	EI 120-U/U E 120-U/U
≤ 160	4,9	≤ 4	---	X	6	EI 120-U/U E 120-U/U

--- ... invalid intumescent inlay
X ... valid intumescent inlay

Pipe penetration seal “BIS Pacifyre® EFC System” - Fire resistance classification -	ANNEX C-12
--	-------------------

Plastic pipes RAUPIANO PLUS acc. to cl. 1.2.1 of the ETA, insulated with Polyethylene sound insulation (e.g. THERMACOMPACT TF™) acc. to cl. 1.1 of the ETA – in flexible walls and rigid walls acc. to cl. 1.2.1 of the ETA

Pipe dimensions (mm)		Insulation thickness (mm)	Intumescent inlay			Fire resistance classification
Outer diameter	Wall thickness		BIS Pacifyre® IM 3	BIS Pacifyre® IM 2	Nr. of layers	
≤ 50	1,8	≤ 4	X	X	2	EI 120-U/C E 120-U/C
≤ 75	1,9	≤ 4	X	X	3	EI 120-U/C E 120-U/C
≤ 110	2,7	≤ 4	X	X	4	EI 120-U/C E 120-U/C
≤ 125	3,1	≤ 4	X	X	5	EI 120-U/C E 120-U/C
≤ 160	3,6	≤ 4	X	X	6	EI 120-U/C E 120-U/C
≤ 50	1,8	≤ 4	---	X	2	EI 120-U/U E 120-U/U
≤ 75	1,9	≤ 4	---	X	3	EI 120-U/U E 120-U/U
≤ 110	2,7	≤ 4	---	X	4	EI 120-U/U E 120-U/U

--- ... invalid intumescent inlay
X ... valid intumescent inlay

Pipe penetration seal
“BIS Pacifyre® EFC System”
- Fire resistance classification -

ANNEX C-13

Plastic pipes Triplus [®] acc. to cl. 1.2.1 of the ETA, insulated with Polyethylene sound insulation (e.g. THERMACOMPACT TF [™]) acc. to cl. 1.1 of the ETA – in flexible walls and rigid walls acc. to cl. 1.2.1 of the ETA						
Pipe dimensions (mm)		Insulation thickness (mm)	Intumescent inlay			Fire resistance classification
Outer diameter	Wall thickness		BIS Pacifyre [®] IM 3	BIS Pacifyre [®] IM 2	Nr. of layers	
≤ 40	1,8	≤ 4	X	X	2	EI 120-U/C E 120-U/C
≤ 75	2,5	≤ 4	X	X	3	EI 120-U/C E 120-U/C
≤ 90	3,1	≤ 4	X	X	4	EI 120-U/C E 120-U/C
≤ 110	3,4	≤ 4	X	X	5	EI 120-U/C E 120-U/C
≤ 125	3,9	≤ 4	X	X	6	EI 120-U/C E 120-U/C
≤ 160	4,9	≤ 4	X	X	8	EI 120-U/C E 120-U/C

X ... valid intumescent inlay

Pipe penetration seal “BIS Pacifyre[®] EFC System” - Fire resistance classification -	ANNEX C-14
---	-------------------

electronic copy

Multiple penetration of maximum three plastic pipes acc. to cl. 1.2.1 of the ETA made from PVC-U, PE-HD or PP through one concerted Pipe collar BIS Pacifyre® EFC (clearance between pipes maximum 15 mm; linear arrangement, no clusters), non-insulated – in flexible walls and rigid walls acc. to cl. 1.2.1 of the ETA

Pipe dimensions (mm)		Insulation thickness (mm)	Intumescent inlay			Fire resistance classification
Outer diameter of each pipe	Wall thickness		BIS Pacifyre® IM 3	BIS Pacifyre® IM 2	Nr. of layers	
≤ 75	1,8 to 8,4	---	X	X	4	EI 120-U/C E 120-U/C

--- ... no insulation allowed
X ... valid intumescent inlay

Metal pipes (copper pipes, steel pipes, stainless steel pipes) acc. to cl. 1.2.1 of the ETA, insulated with AF/Armaflex (length ≥ 500 mm – on both sides of the separating element, local-sustained LS or continued-sustained CS) – in flexible walls and rigid walls acc. to cl. 1.2.1 of the ETA – the intumescent inlay has to be installed on both sides flushed within the separating element (without BIS Pacifyre® EFC Band)

Pipe dimensions (mm)		Insulation thickness (mm)	Intumescent inlay			Fire resistance classification
Outer diameter	Wall thickness		BIS Pacifyre® IM 3	BIS Pacifyre® IM 2	Nr. of layers	
≤ 28	1,0 to 14,2	6,0 to 35,0	X	X	2	EI 120-C/U E 120-C/U
≤ 54	1,5 to 14,2	9,0 to < 35,0	X	X	2	EI 60-C/U E 120-C/U
≤ 54	1,5 to 14,2	35,0	X	X	2	EI 120-C/U E 120-C/U

Metal pipes (copper pipes, steel pipes, stainless steel pipes) acc. to cl. 1.2.1 of the ETA, insulated with AF/Armaflex (length ≥ 500 mm – on both sides of the separating element, local-sustained LS or continued-sustained CS) and an additional layer of AF/Armaflex (length 300 mm, thickness ≥ 9,0 mm – on both sides of the separating element, local-interrupted LI) – in flexible walls and rigid walls acc. to cl. 1.2.1 of the ETA – the intumescent inlay has to be installed on both sides flushed within the separating element (without BIS Pacifyre® EFC Band)

Pipe dimensions (mm)		Insulation thickness (mm)	Intumescent inlay			Fire resistance classification
Outer diameter	Wall thickness		BIS Pacifyre® IM 3	BIS Pacifyre® IM 2	Nr. of layers	
≤ 54	1,5 to 14,2	9,0 to < 35,0	X	X	2	EI 90-C/U E 120-C/U

X ... valid intumescent inlay

Pipe penetration seal “BIS Pacifyre® EFC System” - Fire resistance classification -	ANNEX C-15
--	-------------------

BIS Pacifyre® EFC System – rigid floors according to clause 1.2.1 of the ETA – plastic pipes according to clause 1.2.1 of the ETA, non-insulated, installed in an angle between 90° and 45° – Installation drawing – sectional view

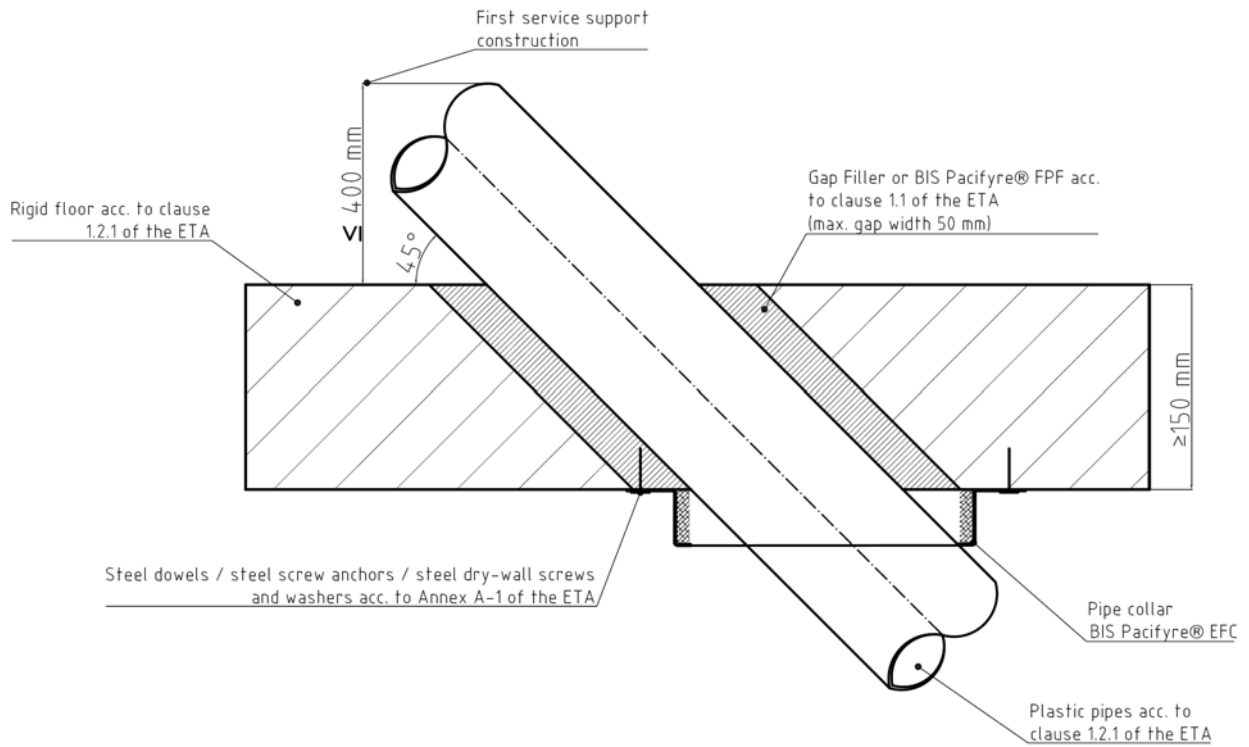

Pipe penetration seal
“BIS Pacifyre® EFC System”
- Installation in rigid floor -

ANNEX D-2

BIS Pacifyre® EFC System – rigid floors according to clause 1.2.1 of the ETA – plastic pipes according to clause 1.2.1 of the ETA, insulated with Polyethylene sound insulation (e.g. THERMACOMPACT TF™) acc. to cl. 1.1 of the ETA – Installation drawing – sectional view

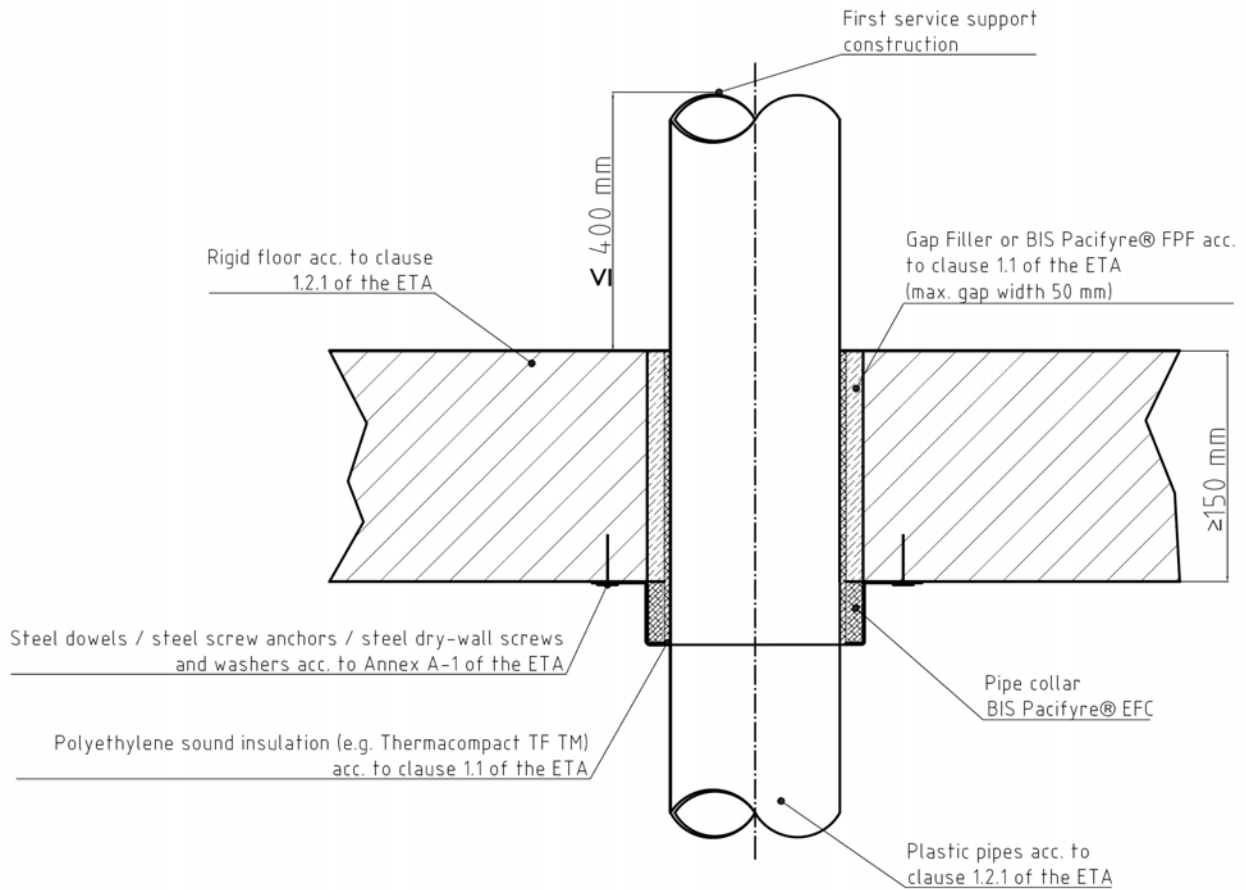

**Pipe penetration seal
“BIS Pacifyre® EFC System”
- Installation in rigid floor -**

ANNEX D-3

electronic copy

BIS Pacifyre® EFC System – rigid floors according to clause 1.2.1 of the ETA – vertical plastic pipes according to clause 1.2.1 of the ETA which are positioned directly in the corner of the wall (clearance between pipe and wall maximum 10 mm), insulated with Polyethylene sound insulation (e.g. THERMACOMPACT TF™) acc. to cl. 1.1 of the ETA – Installation drawing – sectional view

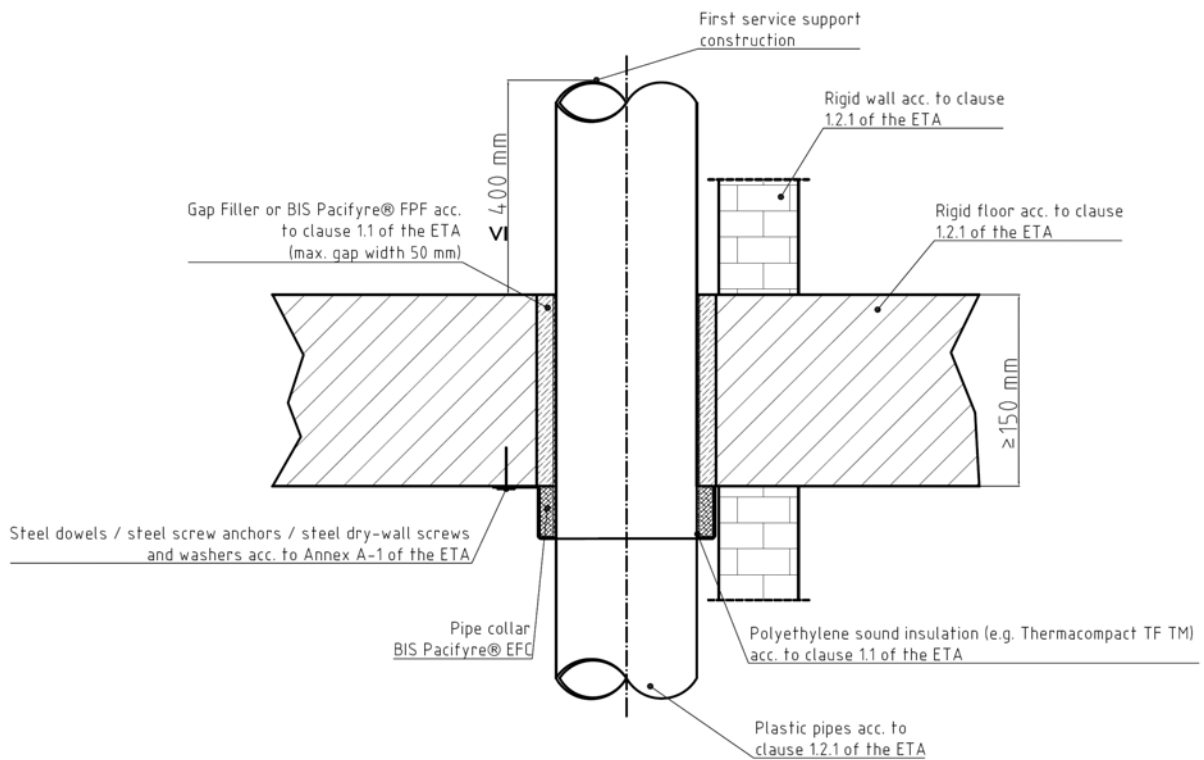

**Pipe penetration seal
“BIS Pacifyre® EFC System”
- Installation in rigid floor -**

ANNEX D-4

electronic copy
electronic copy
electronic copy
electronic copy
electronic copy
electronic copy
electronic copy
electronic copy
electronic copy
electronic copy
electronic copy
electronic copy

BIS Pacifyre® EFC System – rigid floors according to clause 1.2.1 of the ETA – vertical plastic pipes according to clause 1.2.1 of the ETA which are positioned directly in the corner of the wall (clearance between pipe and wall maximum 10 mm), insulated with Polyethylene sound insulation (e.g. THERMACOMPACT TF™) acc. to cl. 1.1 of the ETA – Installation drawing – top view

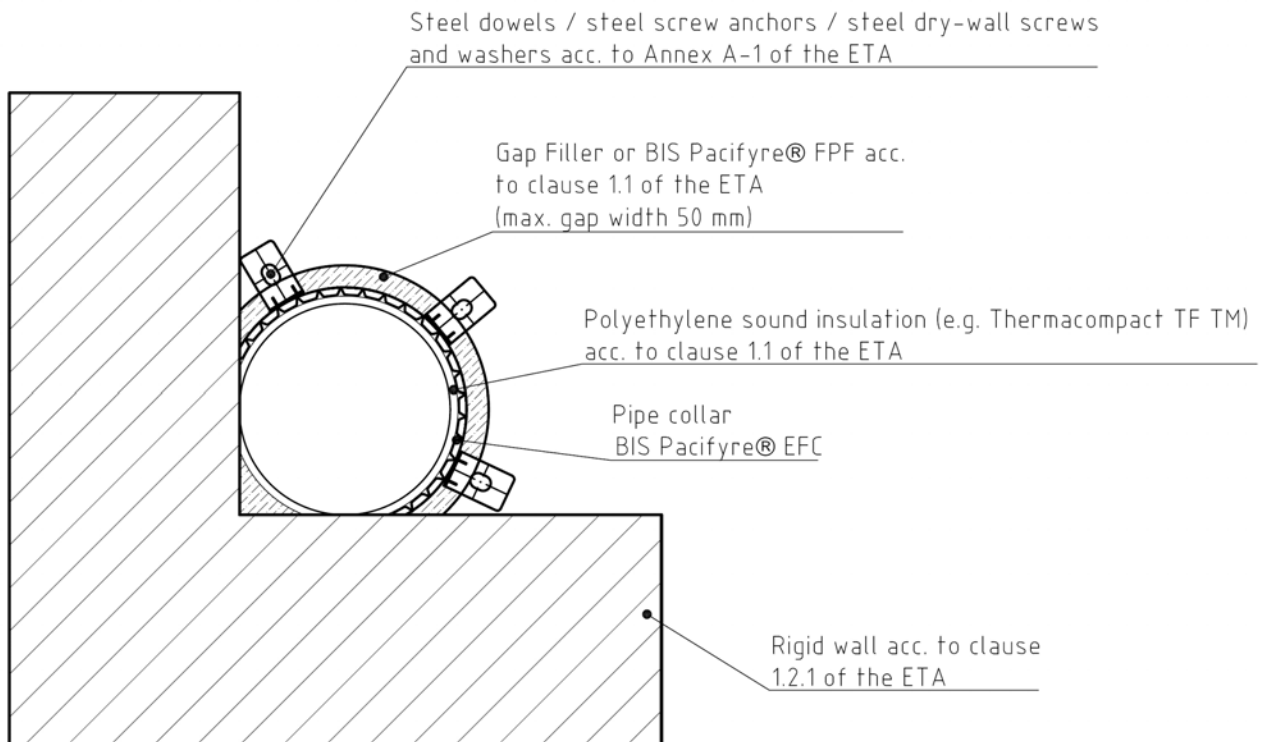

**Pipe penetration seal
“BIS Pacifyre® EFC System”
- Installation in rigid floor -**

ANNEX D-5

BIS Pacifyre® EFC System – rigid floors according to clause 1.2.1 of the ETA – plastic pipes according to clause 1.2.1 of the ETA, insulated with SH/Armaflex or AF/Armaflex – Installation drawing – sectional view

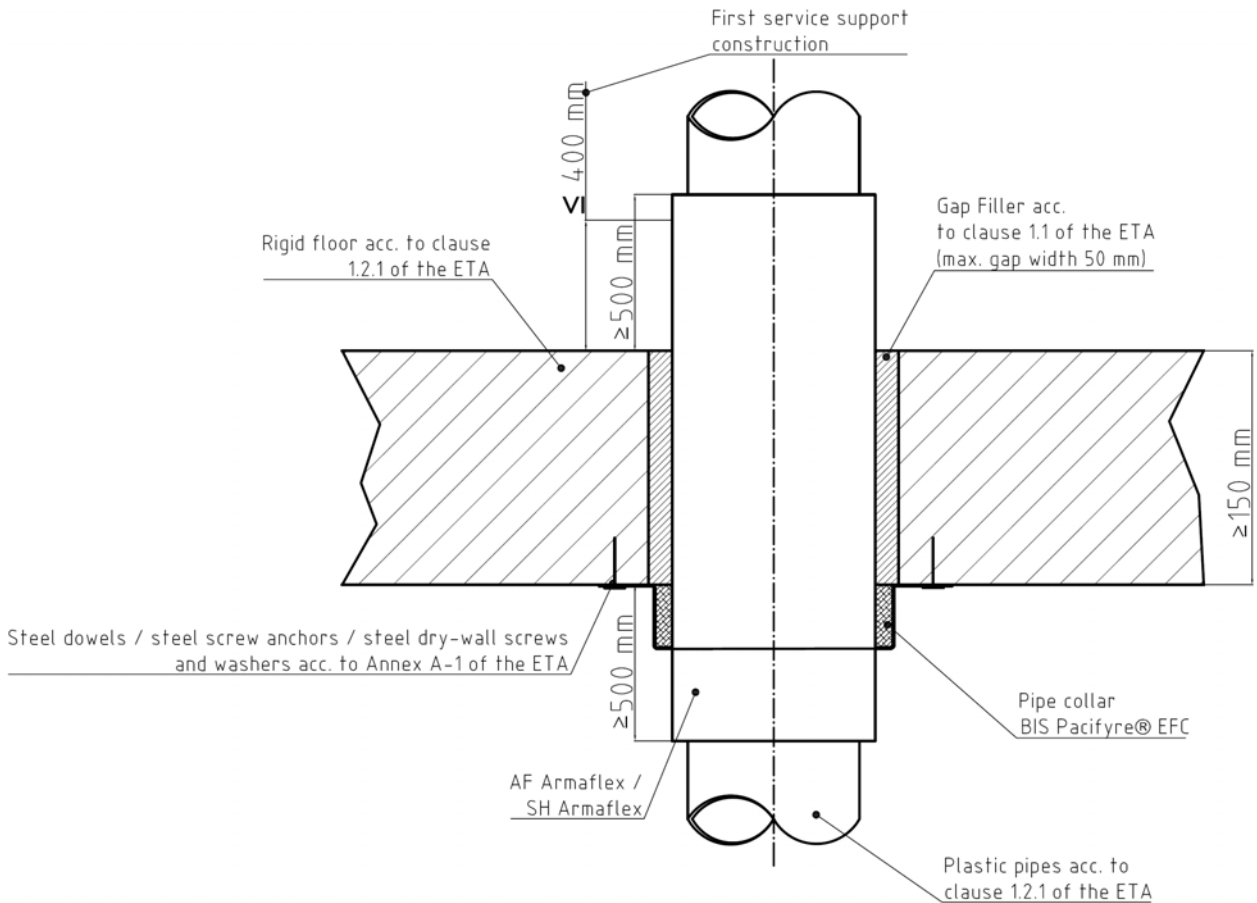

**Pipe penetration seal
“BIS Pacifyre® EFC System”
- Installation in rigid floor -**

ANNEX D-6

BIS Pacifyre® EFC System – rigid floors according to clause 1.2.1 of the ETA – plastic pipes according to clause 1.2.1 of the ETA with bows on the bottom side of the floor and a connection sleeve within the floor, insulated with Polyethylene sound insulation (e.g. THERMACOMPACT TF™) acc. to cl. 1.1 of the ETA – Installation drawing – sectional view

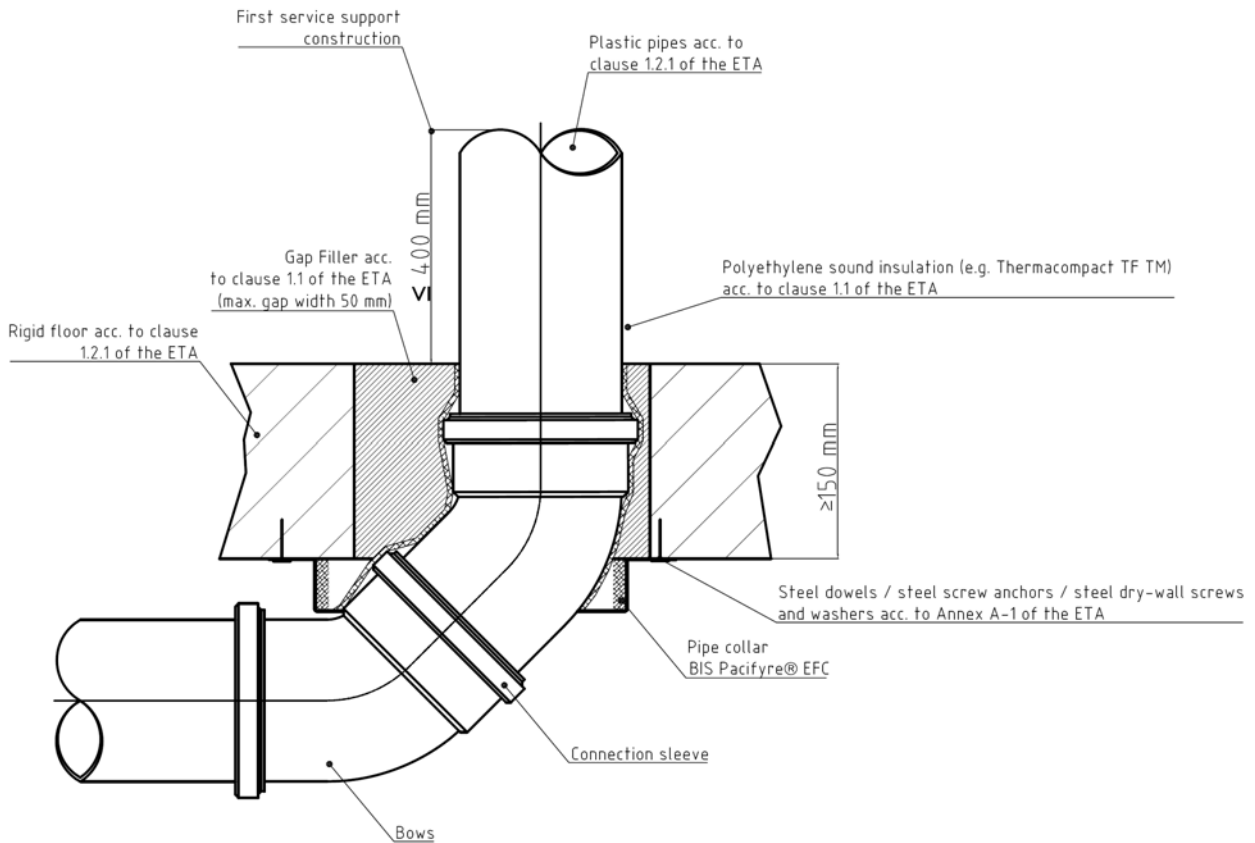

Pipe penetration seal
“BIS Pacifyre® EFC System”
- Installation in rigid floor -

ANNEX D-7

electronic copy electronic copy electronic copy electronic copy electronic copy electronic copy electronic copy electronic copy electronic copy electronic copy

BIS Pacifyre® EFC System – rigid floors according to clause 1.2.1 of the ETA – Multiple penetration of maximum three plastic pipes acc. to cl. 1.2.1 of the ETA made from PVC-U, PE-HD or PP through one concerted Pipe collar BIS Pacifyre® EFC (clearance between pipes maximum 15 mm; linear arrangement, no clusters), non-insulated – Installation drawing – top view

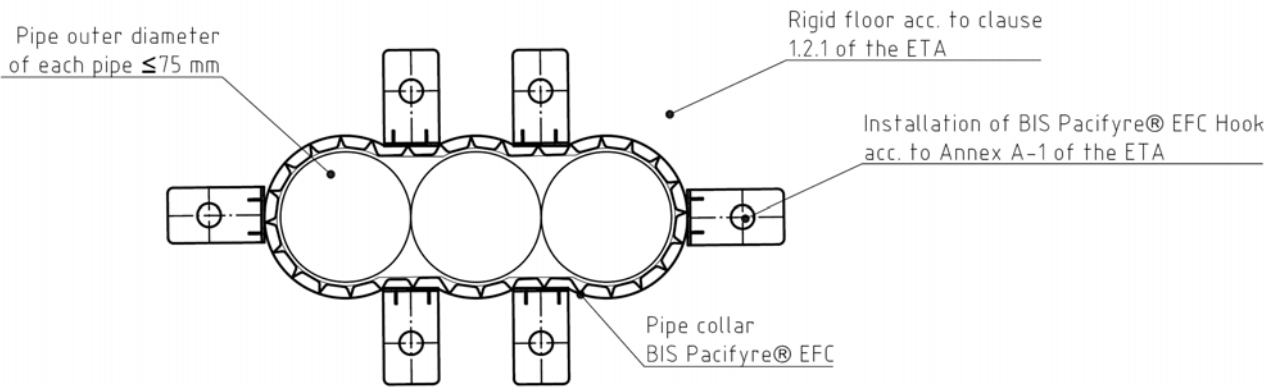

**Pipe penetration seal
“BIS Pacifyre® EFC System”
- Installation in rigid floor -**

ANNEX D-8

BIS Pacifyre® EFC System – rigid floors according to clause 1.2.1 of the ETA – metal pipes according to clause 1.2.1 of the ETA, insulated with AF/Armaflex – intumescent inlays arranged one behind the other at the bottom side flushed within the separating element (without BIS Pacifyre® EFC Band) – Installation drawing – sectional view

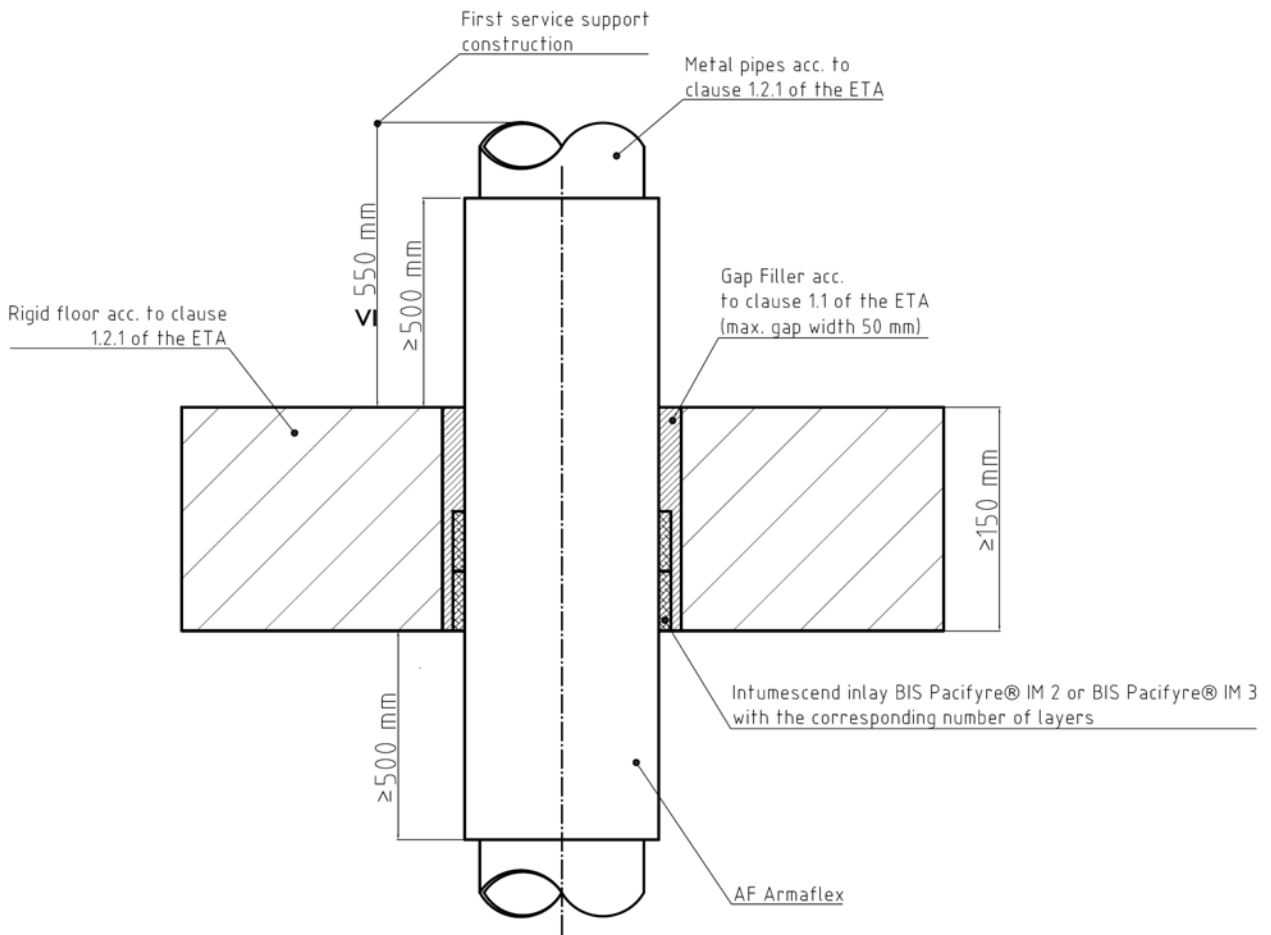

**Pipe penetration seal
“BIS Pacifyre® EFC System”
- Installation in rigid floor -**

ANNEX D-9

BIS Pacifyre® EFC System – rigid floors according to clause 1.2.1 of the ETA – steel pipes and stainless steel pipes according to clause 1.2.1 of the ETA, insulated with AF/Armaflex – Pipe collar BIS Pacifyre® EFC at the bottom side of the separating element – Installation drawing – sectional view

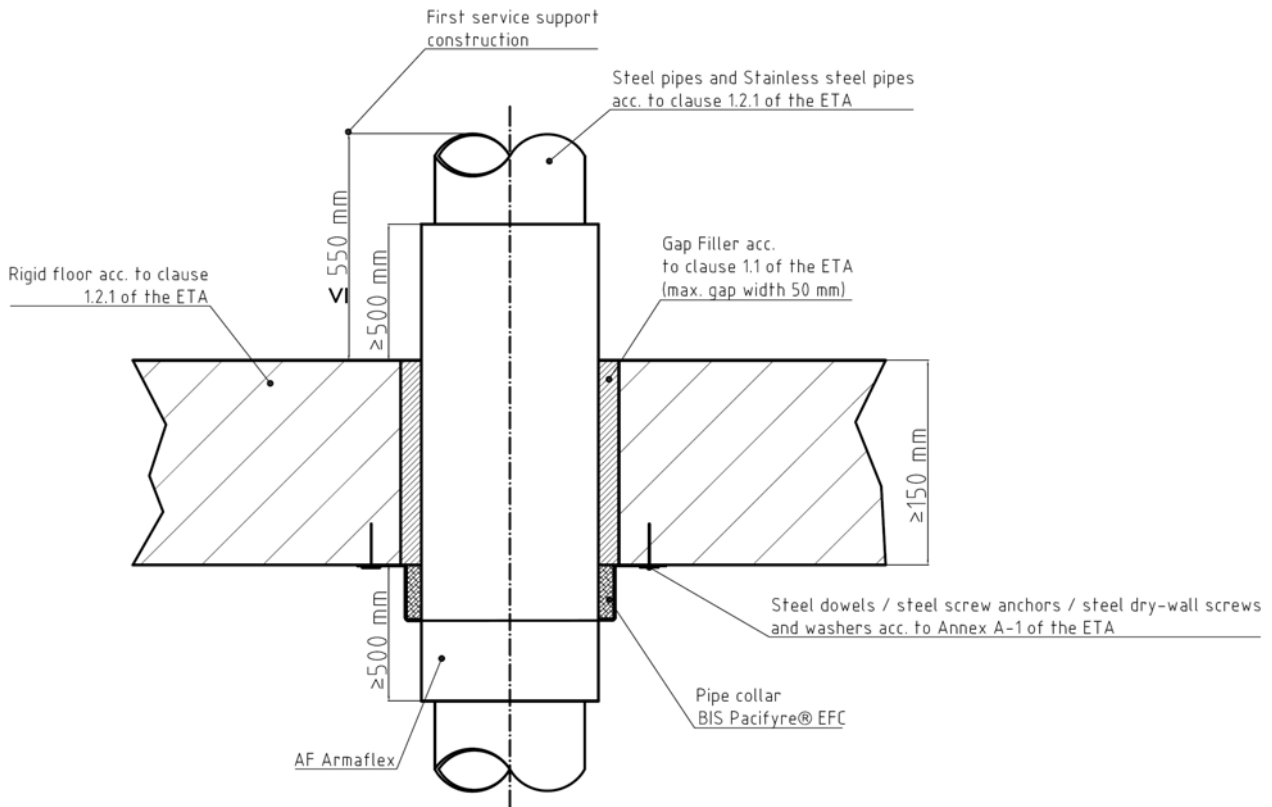

**Pipe penetration seal
“BIS Pacifyre® EFC System”
- Installation in rigid floor -**

ANNEX D-10

electronic copy electronic copy electronic copy electronic copy electronic copy electronic copy electronic copy electronic copy electronic copy electronic copy

PVC-U pipes acc. to cl. 1.2.1 of the ETA, non-insulated – in rigid floors acc. to cl. 1.2.1 of the ETA						
Pipe dimensions (mm)		Insulation thickness (mm)	Intumescent inlay			Fire resistance classification
Outer diameter	Wall thickness		BIS Pacifyre® IM 3	BIS Pacifyre® IM 2	Nr. of layers	
≤ 50	1,8 to 5,6	---	X	X	2	EI 240-U/C E 240-U/C
> 50 to ≤ 75	1,8 to 8,4	---	X	X	3	EI 240-U/C E 240-U/C
> 75 to ≤ 110	1,8 to 12,3	---	X	X	4	EI 240-U/C E 240-U/C
> 110 to ≤ 125	2,2 to 12,1	---	X	X	5	EI 120-U/C E 120-U/C
> 125 to ≤ 160	3,2 to 11,9	---	X	X	6	EI 120-U/C E 120-U/C

PVC-U pipes acc. to cl. 1.2.1 of the ETA, non-insulated, installed in an angle between 90° and 45° – in rigid floors acc. to cl. 1.2.1 of the ETA						
Pipe dimensions (mm)		Insulation thickness (mm)	Intumescent inlay			Fire resistance classification
Outer diameter	Wall thickness		BIS Pacifyre® IM 3	BIS Pacifyre® IM 2	Nr. of layers	
≤ 50	1,8	---	X	X	2	EI 120-U/C E 120-U/C
> 75 to ≤ 110	12,3	---	X	X	4	EI 120-U/C E 120-U/C
> 110 to ≤ 125	12,1	---	X	X	5	EI 120-U/C E 120-U/C
> 125 to ≤ 160	11,9	---	X	X	6	EI 120-U/C E 120-U/C
> 125 to ≤ 160	3,2	---	X	X	8	EI 120-U/C E 120-U/C

--- ... no insulation allowed
X ... valid intumescent inlay

Pipe penetration seal “BIS Pacifyre® EFC System” - Fire resistance classification -	ANNEX E-1
--	------------------

electronic copy electronic copy electronic copy electronic copy electronic copy electronic copy electronic copy electronic copy electronic copy electronic copy

PE-HD pipes acc. to cl. 1.2.1 of the ETA, non-insulated – in rigid floors acc. to cl. 1.2.1 of the ETA						
Pipe dimensions (mm)		Insulation thickness (mm)	Intumescent inlay			Fire resistance classification
Outer diameter	Wall thickness		BIS Pacifyre® IM 3	BIS Pacifyre® IM 2	Nr. of layers	
≤ 50	1,8 to 4,6	---	X	X	2	EI 240-U/C E 240-U/C
> 50 to ≤ 75	1,8 to 8,4	---	X	X	3	EI 240-U/C E 240-U/C
> 75 to ≤ 110	> 2,7 to 10,0	---	X	X	4	EI 180-U/C E 240-U/C
> 110 to ≤ 160	> 4,0 to 14,6	---	X	X	6	EI 120-U/C E 240-U/C

PE-HD pipes acc. to cl. 1.2.1 of the ETA, non-insulated, installed in an angle between 90° and 45° – in rigid floors acc. to cl. 1.2.1 of the ETA						
Pipe dimensions (mm)		Insulation thickness (mm)	Intumescent inlay			Fire resistance classification
Outer diameter	Wall thickness		BIS Pacifyre® IM 3	BIS Pacifyre® IM 2	Nr. of layers	
≤ 50	4,6	---	X	X	2	EI 120-U/C E 120-U/C
> 50 to ≤ 110	2,7 to 10,0	---	X	X	4	EI 120-U/C E 120-U/C

--- ... no insulation allowed
X ... valid intumescent inlay

Pipe penetration seal
“BIS Pacifyre® EFC System”
- Fire resistance classification -

ANNEX E-2

electronic copy electronic copy electronic copy electronic copy electronic copy electronic copy electronic copy electronic copy electronic copy electronic copy

PE-HD pipes acc. to cl. 1.2.1 of the ETA, insulated with Polyethylene sound insulation (e.g. THERMACOMPACT TF™) acc. to cl. 1.1 of the ETA – in rigid floors acc. to cl. 1.2.1 of the ETA						
Pipe dimensions (mm)		Insulation thickness (mm)	Intumescent inlay			Fire resistance classification
Outer diameter	Wall thickness		BIS Pacifyre® IM 3	BIS Pacifyre® IM 2	Nr. of layers	
≤ 50	1,8	≤ 4	X	X	2	EI 120-U/C E 120-U/C
>50 to ≤ 75	2,2	≤ 4	X	X	3	EI 120-U/C E 120-U/C
> 75 to ≤ 110	2,7 to 10,0	≤ 4	X	X	4	EI 120-U/C E 120-U/C

PE-HD pipes acc. to cl. 1.2.1 of the ETA, positioned vertically directly in the corner of the wall (clearance between pipe and wall maximum 10 mm), insulated with Polyethylene sound insulation (e.g. THERMACOMPACT TF™) acc. to cl. 1.1 of the ETA – in rigid floors acc. to cl. 1.2.1 of the ETA						
Pipe dimensions (mm)		Insulation thickness (mm)	Intumescent inlay			Fire resistance classification
Outer diameter	Wall thickness		BIS Pacifyre® IM 3	BIS Pacifyre® IM 2	Nr. of layers	
≤ 110	10,0	≤ 4	X	X	4	EI 120-U/C E 120-U/C

X ... valid intumescent inlay

<p>Pipe penetration seal “BIS Pacifyre® EFC System” - Fire resistance classification -</p>	<p>ANNEX E-3</p>
---	-------------------------

PP pipes acc. to cl. 1.2.1 of the ETA, non-insulated – in rigid floors acc. to cl. 1.2.1 of the ETA						
Pipe dimensions (mm)		Insulation thickness (mm)	Intumescent inlay			Fire resistance classification
Outer diameter	Wall thickness		BIS Pacifyre® IM 3	BIS Pacifyre® IM 2	Nr. of layers	
≤ 50	1,8 to 4,6	---	X	X	2	EI 240-U/C E 240-U/C
> 50 to ≤ 75	1,8 to 8,4	---	X	X	3	EI 240-U/C E 240-U/C
> 75 to ≤ 110	> 2,7 to 10,0	---	X	X	4	EI 180-U/C E 180-U/C
> 110 to ≤ 125	> 3,1 to 11,4	---	X	X	6	EI 120-U/C E 120-U/C
> 125 to ≤ 160	> 4,0 to 14,6	---	X	X	8	EI 120-U/C E 120-U/C

PP pipes acc. to cl. 1.2.1 of the ETA, non-insulated, installed in an angle between 90° and 45° – in rigid floors acc. to cl. 1.2.1 of the ETA						
Pipe dimensions (mm)		Insulation thickness (mm)	Intumescent inlay			Fire resistance classification
Outer diameter	Wall thickness		BIS Pacifyre® IM 3	BIS Pacifyre® IM 2	Nr. of layers	
≤ 110	2,7 to 10,0	---	X	X	4	EI 120-U/C E 120-U/C
> 110 to ≤ 125	3,2 to 12,0	---	X	X	6	EI 120-U/C E 120-U/C
> 125 to ≤ 160	4,0 to 14,6	---	X	X	8	EI 120-U/C E 120-U/C

--- ... no insulation allowed
X ... valid intumescent inlay

PP pipes acc. to cl. 1.2.1 of the ETA, positioned vertically directly in the corner of the wall (clearance between pipe and wall maximum 10 mm), insulated with Polyethylene sound insulation (e.g. THERMACOMPACT TF™) acc. to cl. 1.1 of the ETA – in rigid floors acc. to cl. 1.2.1 of the ETA						
Pipe dimensions (mm)		Insulation thickness (mm)	Intumescent inlay			Fire resistance classification
Outer diameter	Wall thickness		BIS Pacifyre® IM 3	BIS Pacifyre® IM 2	Nr. of layers	
≤ 110	2,7	≤ 4	X	X	4	EI 120-U/C E 120-U/C

X ... valid intumescent inlay

Pipe penetration seal “BIS Pacifyre® EFC System” - Fire resistance classification -	ANNEX E-4
--	------------------

electronic copy

Plastic pipes alpex F50 PROFI and alpex L acc. to cl. 1.2.1 of the ETA, non-insulated – in rigid floors acc. to cl. 1.2.1 of the ETA						
Pipe dimensions (mm)		Insulation thickness (mm)	Intumescent inlay			Fire resistance classification
Outer diameter	Wall thickness		BIS Pacifyre® IM 3	BIS Pacifyre® IM 2	Nr. of layers	
≤ 16	2,0	---	X	X	2	EI 120-U/C E 120-U/C
≤ 50	4,0	---	X	X	2	EI 120-U/C E 120-U/C
≤ 75	5,0	---	X	X	4	EI 120-U/C E 120-U/C

--- ... no insulation allowed
X ... valid intumescent inlay

Plastic pipes alpex F50 PROFI and alpex L acc. to cl. 1.2.1 of the ETA, insulated with SH/Armaflex (length ≥ 500 mm – on both sides of the separating element, local-sustained LS or continued-sustained CS) – in rigid floors acc. to cl. 1.2.1 of the ETA						
Pipe dimensions (mm)		Insulation thickness (mm)	Intumescent inlay			Fire resistance classification
Outer diameter	Wall thickness		BIS Pacifyre® IM 3	BIS Pacifyre® IM 2	Nr. of layers	
≤ 16	2,0	9,0	X	X	2	EI 120-U/C E 120-U/C
≤ 75	5,0	9,0	X	X	4	EI 120-U/C E 120-U/C
≤ 75	5,0	> 9,0 to 20,0	X	X	5	EI 120-U/C E 120-U/C
≤ 75	5,0	> 20,0 to 30,0	X	X	6	EI 120-U/C E 120-U/C

Plastic pipes alpex F50 PROFI and alpex L acc. to cl. 1.2.1 of the ETA, insulated with AF/Armaflex (length ≥ 500 mm – on both sides of the separating element, local-sustained LS or continued-sustained CS) – in rigid floors acc. to cl. 1.2.1 of the ETA						
Pipe dimensions (mm)		Insulation thickness (mm)	Intumescent inlay			Fire resistance classification
Outer diameter	Wall thickness		BIS Pacifyre® IM 3	BIS Pacifyre® IM 2	Nr. of layers	
≤ 75	5,0	9,5	X	X	4	EI 120-U/C E 120-U/C

X ... valid intumescent inlay

Pipe penetration seal “BIS Pacifyre® EFC System” - Fire resistance classification -	ANNEX E-5
--	------------------

electronic copy electronic copy electronic copy electronic copy electronic copy electronic copy electronic copy electronic copy electronic copy electronic copy

Plastic pipes BluePower [®] acc. to cl. 1.2.1 of the ETA, insulated with Polyethylene sound insulation (e.g. THERMACOMPACT TF [™]) acc. to cl. 1.1 of the ETA – in rigid floors acc. to cl. 1.2.1 of the ETA						
Pipe dimensions (mm)		Insulation thickness (mm)	Intumescent inlay			Fire resistance classification
Outer diameter	Wall thickness		BIS Pacifyre [®] IM 3	BIS Pacifyre [®] IM 2	Nr. of layers	
≤ 50	1,8	≤ 4	X	X	2	EI 120-U/C E 120-U/C
≤ 75	2,5	≤ 4	X	X	4	EI 90-U/C E 90-U/C
≤ 110	3,4	≤ 4	X	X	5	EI 90-U/C E 90-U/C

X ... valid intumescent inlay

<p>Pipe penetration seal “BIS Pacifyre[®] EFC System” - Fire resistance classification -</p>	<p>ANNEX E-6</p>
--	-------------------------

electronic copy

Plastic pipes Uponor Unipipe Mehrschichtverbundrohr MLC acc. to cl. 1.2.1 of the ETA, non-insulated – in rigid floors acc. to cl. 1.2.1 of the ETA						
Pipe dimensions (mm)		Insulation thickness (mm)	Intumescent inlay			Fire resistance classification
Outer diameter	Wall thickness		BIS Pacifyre® IM 3	BIS Pacifyre® IM 2	Nr. of layers	
≤ 50	4,5	---	X	X	2	EI 120-U/C E 120-U/C
≤ 75	7,5	---	X	X	3	EI 90-U/C E 90-U/C
≤ 110	10,0	---	X	X	4	EI 90-U/C E 90-U/C

--- ... no insulation allowed
X ... valid intumescent inlay

Plastic pipes Uponor Unipipe Mehrschichtverbundrohr MLC acc. to cl. 1.2.1 of the ETA, insulated with SH/Armaflex (length ≥ 500 mm – on both sides of the separating element, local-sustained LS or continued-sustained CS) – in rigid floors acc. to cl. 1.2.1 of the ETA						
Pipe dimensions (mm)		Insulation thickness (mm)	Intumescent inlay			Fire resistance classification
Outer diameter	Wall thickness		BIS Pacifyre® IM 3	BIS Pacifyre® IM 2	Nr. of layers	
≤ 50	4,5	10,0	X	X	3	EI 120-U/C E 120-U/C
≤ 63	6,0	9,0	X	X	4	EI 120-U/C E 120-U/C
≤ 90	8,5	9,0	X	X	5	EI 120-U/C E 120-U/C
≤ 110	10,0	> 9,0 to 20,0	X	X	6	EI 120-U/C E 120-U/C

Plastic pipes Uponor Unipipe Mehrschichtverbundrohr MLC acc. to cl. 1.2.1 of the ETA, insulated with AF/Armaflex (length ≥ 500 mm – on both sides of the separating element, local-sustained LS or continued-sustained CS) – in rigid floors acc. to cl. 1.2.1 of the ETA						
Pipe dimensions (mm)		Insulation thickness (mm)	Intumescent inlay			Fire resistance classification
Outer diameter	Wall thickness		BIS Pacifyre® IM 3	BIS Pacifyre® IM 2	Nr. of layers	
≤ 50	4,5	27,5	X	X	4	EI 120-U/C E 120-U/C
≤ 75	7,5	30,0	X	X	5	EI 120-U/C E 120-U/C
≤ 110	10,0	9,5 to 31,0	X	X	6	EI 120-U/C E 120-U/C

X ... valid intumescent inlay

Pipe penetration seal “BIS Pacifyre® EFC System” - Fire resistance classification -	ANNEX E-7
--	------------------

electronic copy electronic copy electronic copy electronic copy electronic copy electronic copy electronic copy electronic copy electronic copy electronic copy

Plastic pipes Wavin SiTech [®] acc. to cl. 1.2.1 of the ETA, insulated with Polyethylene sound insulation (e.g. THERMACOMPACT TF [™]) acc. to cl. 1.1 of the ETA – in rigid floors acc. to cl. 1.2.1 of the ETA						
Pipe dimensions (mm)		Insulation thickness (mm)	Intumescent inlay			Fire resistance classification
Outer diameter	Wall thickness		BIS Pacifyre [®] IM 3	BIS Pacifyre [®] IM 2	Nr. of layers	
≤ 50	2,0	≤ 4	X	X	2	EI 120-U/C E 120-U/C
≤ 75	2,6	≤ 4	X	X	3	EI 120-U/C E 120-U/C
≤ 110	3,6	≤ 4	X	X	4	EI 120-U/C E 120-U/C
≤ 125	4,2	≤ 4	X	X	5	EI 60-U/C E 60-U/C
≤ 160	5,3	≤ 4	X	X	6	EI 60-U/C E 60-U/C
≤ 50	2,0	≤ 4	---	X	2	EI 120-U/U E 120-U/U
≤ 75	2,6	≤ 4	---	X	3	EI 120-U/U E 120-U/U
≤ 110	3,6	≤ 4	---	X	4	EI 120-U/U E 120-U/U
≤ 125	4,2	≤ 4	---	X	5	EI 120-U/U E 120-U/U
≤ 160	5,3	≤ 4	---	X	6	EI 120-U/U E 120-U/U
--- ... invalid intumescent inlay X ... valid intumescent inlay						
Plastic pipes Wavin SiTech [®] acc. to cl. 1.2.1 of the ETA, positioned vertically directly in the corner of the wall (clearance between pipe and wall maximum 10 mm), insulated with Polyethylene sound insulation (e.g. THERMACOMPACT TF [™]) acc. to cl. 1.1 of the ETA – in rigid floors acc. to cl. 1.2.1 of the ETA						
Pipe dimensions (mm)		Insulation thickness (mm)	Intumescent inlay			Fire resistance classification
Outer diameter	Wall thickness		BIS Pacifyre [®] IM 3	BIS Pacifyre [®] IM 2	Nr. of layers	
≤ 110	3,6	≤ 4	---	X	5	EI 120-U/U E 120-U/U
--- ... invalid intumescent inlay X ... valid intumescent inlay						
Plastic pipes Wavin SiTech [®] acc. to cl. 1.2.1 of the ETA, with bows on the bottom side of the floor and a connection sleeve within the floor, insulated with Polyethylene sound insulation (e.g. THERMACOMPACT TF [™]) acc. to cl. 1.1 of the ETA – in rigid floors acc. to cl. 1.2.1 of the ETA						
Pipe dimensions (mm)		Insulation thickness (mm)	Intumescent inlay			Fire resistance classification
Outer diameter	Wall thickness		BIS Pacifyre [®] IM 3	BIS Pacifyre [®] IM 2	Nr. of layers	
≤ 50	2,0	≤ 4	---	X	3	EI 120-U/U E 120-U/U
≤ 75	2,6	≤ 4	---	X	4	EI 120-U/U E 120-U/U
≤ 110	3,6	≤ 4	---	X	5	EI 120-U/U E 120-U/U
--- ... invalid intumescent inlay X ... valid intumescent inlay						
Pipe penetration seal “BIS Pacifyre[®] EFC System” - Fire resistance classification -						ANNEX E-8

electronic copy electronic copy electronic copy electronic copy electronic copy electronic copy electronic copy electronic copy electronic copy electronic copy

Plastic pipes Fusiotherm® Stabverbundrohr acc. to cl. 1.2.1 of the ETA, non-insulated – in rigid floors acc. to cl. 1.2.1 of the ETA						
Pipe dimensions (mm)		Insulation thickness (mm)	Intumescent inlay			Fire resistance classification
Outer diameter	Wall thickness		BIS Pacifyre® IM 3	BIS Pacifyre® IM 2	Nr. of layers	
≤ 16	2,2	---	X	X	2	EI 120-U/C E 120-U/C
≤ 50	7,9	---	X	X	2	EI 120-U/C E 120-U/C
≤ 75	11,8	---	X	X	3	EI 120-U/C E 120-U/C
≤ 110	17,2	---	X	X	4	EI 120-U/C E 120-U/C
--- ... no insulation allowed X ... valid intumescent inlay						
Plastic pipes Fusiotherm® Stabverbundrohr acc. to cl. 1.2.1 of the ETA, insulated with SH/Armaflex (length ≥ 500 mm – on both sides of the separating element, local-sustained LS or continued-sustained CS) – in rigid floors acc. to cl. 1.2.1 of the ETA						
Pipe dimensions (mm)		Insulation thickness (mm)	Intumescent inlay			Fire resistance classification
Outer diameter	Wall thickness		BIS Pacifyre® IM 3	BIS Pacifyre® IM 2	Nr. of layers	
≤ 50	6,9	10,0	X	X	3	EI 120-U/C E 120-U/C
Plastic pipes Fusiotherm® Stabverbundrohr acc. to cl. 1.2.1 of the ETA, insulated with AF/Armaflex (length ≥ 500 mm – on both sides of the separating element, local-sustained LS or continued-sustained CS) – in rigid floors acc. to cl. 1.2.1 of the ETA						
Pipe dimensions (mm)		Insulation thickness (mm)	Intumescent inlay			Fire resistance classification
Outer diameter	Wall thickness		BIS Pacifyre® IM 3	BIS Pacifyre® IM 2	Nr. of layers	
≤ 110	15,2	31,0	X	X	6	EI 120-U/C E 120-U/C
X ... valid intumescent inlay						
Plastic pipes Fusiotherm® SDR 11 acc. to cl. 1.2.1 of the ETA, non-insulated – in rigid floors acc. to cl. 1.2.1 of the ETA						
Pipe dimensions (mm)		Insulation thickness (mm)	Intumescent inlay			Fire resistance classification
Outer diameter	Wall thickness		BIS Pacifyre® IM 3	BIS Pacifyre® IM 2	Nr. of layers	
≤ 315	28,6	---	X	X	20	EI 120-U/C E 120-U/C
--- ... no insulation allowed X ... valid intumescent inlay						
Pipe penetration seal “BIS Pacifyre® EFC System” - Fire resistance classification -						ANNEX E-9

electronic copy

Plastic pipes Geberit Silent-PP acc. to cl. 1.2.1 of the ETA, insulated with Polyethylene sound insulation (e.g. THERMACOMPACT TF™) acc. to cl. 1.1 of the ETA – in rigid floors acc. to cl. 1.2.1 of the ETA

Pipe dimensions (mm)		Insulation thickness (mm)	Intumescent inlay			Fire resistance classification
Outer diameter	Wall thickness		BIS Pacifyre® IM 3	BIS Pacifyre® IM 2	Nr. of layers	
≤ 50	2,0	≤ 4	X	X	2	EI 120-U/C E 120-U/C
≤ 75	2,6	≤ 4	X	X	3	EI 120-U/C E 120-U/C
≤ 110	3,6	≤ 4	X	X	4	EI 120-U/C E 120-U/C
≤ 50	2,0	≤ 4	---	X	2	EI 120-U/U E 120-U/U
≤ 75	2,6	≤ 4	---	X	3	EI 120-U/U E 120-U/U
≤ 110	3,6	≤ 4	---	X	4	EI 120-U/U E 120-U/U
≤ 125	4,2	≤ 4	---	X	5	EI 120-U/U E 120-U/U
≤ 160	5,2	≤ 4	---	X	6	EI 120-U/U E 120-U/U

Plastic pipes Geberit Silent-PP acc. to cl. 1.2.1 of the ETA, positioned vertically directly in the corner of the wall (clearance between pipe and wall maximum 10 mm), insulated with Polyethylene sound insulation (e.g. THERMACOMPACT TF™) acc. to cl. 1.1 of the ETA – in rigid floors acc. to cl. 1.2.1 of the ETA

Pipe dimensions (mm)		Insulation thickness (mm)	Intumescent inlay			Fire resistance classification
Outer diameter	Wall thickness		BIS Pacifyre® IM 3	BIS Pacifyre® IM 2	Nr. of layers	
≤ 110	3,6	≤ 4	---	X	5	EI 120-U/U E 120-U/U

Plastic pipes Geberit Silent-PP acc. to cl. 1.2.1 of the ETA, with bows on the bottom side of the floor and a connection sleeve within the floor, insulated with Polyethylene sound insulation (e.g. THERMACOMPACT TF™) acc. to cl. 1.1 of the ETA – in rigid floors acc. to cl. 1.2.1 of the ETA

Pipe dimensions (mm)		Insulation thickness (mm)	Intumescent inlay			Fire resistance classification
Outer diameter	Wall thickness		BIS Pacifyre® IM 3	BIS Pacifyre® IM 2	Nr. of layers	
≤ 50	2,0	≤ 4	---	X	3	EI 120-U/U E 120-U/U
≤ 75	2,6	≤ 4	---	X	4	EI 120-U/U E 120-U/U
≤ 110	3,6	≤ 4	---	X	5	EI 120-U/U E 120-U/U

--- ... invalid intumescent inlay
X ... valid intumescent inlay

Pipe penetration seal
“BIS Pacifyre® EFC System”
- Fire resistance classification -

ANNEX E-10

Plastic pipes POLO-KAL NG acc. to cl. 1.2.1 of the ETA, insulated with Polyethylene sound insulation (e.g. THERMACOMPACT TF™) acc. to cl. 1.1 of the ETA – in rigid floors acc. to cl. 1.2.1 of the ETA						
Pipe dimensions (mm)		Insulation thickness (mm)	Intumescent inlay			Fire resistance classification
Outer diameter	Wall thickness		BIS Pacifyre® IM 3	BIS Pacifyre® IM 2	Nr. of layers	
≤ 50	2,0	≤ 4	X	X	2	EI 90-U/C E 120-U/C
≤ 75	2,6	≤ 4	X	X	3	EI 90-U/C E 120-U/C
≤ 110	3,4	≤ 4	X	X	4	EI 120-U/C E 120-U/C
≤ 50	2,0	≤ 4	---	X	2	EI 120-U/U E 120-U/U
≤ 75	2,6	≤ 4	---	X	3	EI 120-U/U E 120-U/U
≤ 110	3,4	≤ 4	---	X	4	EI 120-U/U E 120-U/U
≤ 125	3,9	≤ 4	---	X	5	EI 120-U/U E 120-U/U
≤ 160	4,9	≤ 4	---	X	6	EI 120-U/U E 120-U/U

Plastic pipes POLO-KAL NG acc. to cl. 1.2.1 of the ETA, positioned vertically directly in the corner of the wall (clearance between pipe and wall maximum 10 mm), insulated with Polyethylene sound insulation (e.g. THERMACOMPACT TF™) acc. to cl. 1.1 of the ETA – in rigid floors acc. to cl. 1.2.1 of the ETA						
Pipe dimensions (mm)		Insulation thickness (mm)	Intumescent inlay			Fire resistance classification
Outer diameter	Wall thickness		BIS Pacifyre® IM 3	BIS Pacifyre® IM 2	Nr. of layers	
≤ 110	3,4	≤ 4	---	X	5	EI 120-U/U E 120-U/U

Plastic pipes POLO-KAL NG acc. to cl. 1.2.1 of the ETA, with bows on the bottom side of the floor and a connection sleeve within the floor, insulated with Polyethylene sound insulation (e.g. THERMACOMPACT TF™) acc. to cl. 1.1 of the ETA – in rigid floors acc. to cl. 1.2.1 of the ETA						
Pipe dimensions (mm)		Insulation thickness (mm)	Intumescent inlay			Fire resistance classification
Outer diameter	Wall thickness		BIS Pacifyre® IM 3	BIS Pacifyre® IM 2	Nr. of layers	
≤ 50	2,0	≤ 4	---	X	3	EI 120-U/U E 120-U/U
≤ 75	2,6	≤ 4	---	X	4	EI 120-U/U E 120-U/U
≤ 110	3,4	≤ 4	---	X	5	EI 120-U/U E 120-U/U

--- ... invalid intumescent inlay
X ... valid intumescent inlay

Pipe penetration seal “BIS Pacifyre® EFC System” - Fire resistance classification -	ANNEX E-11
--	-------------------

electronic copy

Plastic pipes RAUPIANO PLUS acc. to cl. 1.2.1 of the ETA, insulated with Polyethylene sound insulation (e.g. THERMACOMPACT TF™) acc. to cl. 1.1 of the ETA – in rigid floors acc. to cl. 1.2.1 of the ETA

Pipe dimensions (mm)		Insulation thickness (mm)	Intumescent inlay			Fire resistance classification
Outer diameter	Wall thickness		BIS Pacifyre® IM 3	BIS Pacifyre® IM 2	Nr. of layers	
≤ 50	1,8	≤ 4	---	X	2	EI 120-U/U E 120-U/U
≤ 75	1,9	≤ 4	---	X	3	EI 120-U/U E 120-U/U
≤ 110	2,7	≤ 4	---	X	4	EI 120-U/U E 120-U/U
≤ 125	3,1	≤ 4	---	X	5	EI 120-U/U E 120-U/U
≤ 160	3,6	≤ 4	---	X	6	EI 120-U/U E 120-U/U

Plastic pipes RAUPIANO PLUS acc. to cl. 1.2.1 of the ETA, positioned vertically directly in the corner of the wall (clearance between pipe and wall maximum 10 mm), insulated with Polyethylene sound insulation (e.g. THERMACOMPACT TF™) acc. to cl. 1.1 of the ETA – in rigid floors acc. to cl. 1.2.1 of the ETA

Pipe dimensions (mm)		Insulation thickness (mm)	Intumescent inlay			Fire resistance classification
Outer diameter	Wall thickness		BIS Pacifyre® IM 3	BIS Pacifyre® IM 2	Nr. of layers	
≤ 110	2,7	≤ 4	---	X	5	EI 120-U/U E 120-U/U

Plastic pipes RAUPIANO PLUS acc. to cl. 1.2.1 of the ETA, with bows on the bottom side of the floor and a connection sleeve within the floor, insulated with Polyethylene sound insulation (e.g. THERMACOMPACT TF™) acc. to cl. 1.1 of the ETA – in rigid floors acc. to cl. 1.2.1 of the ETA

Pipe dimensions (mm)		Insulation thickness (mm)	Intumescent inlay			Fire resistance classification
Outer diameter	Wall thickness		BIS Pacifyre® IM 3	BIS Pacifyre® IM 2	Nr. of layers	
≤ 50	2,0	≤ 4	---	X	3	EI 120-U/U E 120-U/U
≤ 75	2,6	≤ 4	---	X	4	EI 120-U/U E 120-U/U
≤ 110	2,7	≤ 4	---	X	5	EI 120-U/U E 120-U/U

--- ... invalid intumescent inlay
X ... valid intumescent inlay

Pipe penetration seal
“BIS Pacifyre® EFC System”
- Fire resistance classification -

ANNEX E-12

Multiple penetration of maximum three plastic pipes acc. to cl. 1.2.1 of the ETA made from PVC-U, PE-HD or PP through one concerted Pipe collar BIS Pacifyre® EFC (clearance between pipes maximum 15 mm; linear arrangement, no clusters), non-insulated – in rigid floors acc. to cl. 1.2.1 of the ETA

Pipe dimensions (mm)		Insulation thickness (mm)	Intumescent inlay			Fire resistance classification
Outer diameter of each pipe	Wall thickness		BIS Pacifyre® IM 3	BIS Pacifyre® IM 2	Nr. of layers	
≤ 75	1,8 to 8,4	---	X	X	4	EI 120-U/C E 120-U/C

--- ... no insulation allowed
X ... valid intumescent inlay

Metal pipes (copper pipes, steel pipes, stainless steel pipes) acc. to cl. 1.2.1 of the ETA, insulated with AF/Armaflex (length ≥ 500 mm – on both sides of the separating element, local-sustained LS or continued-sustained CS) – in rigid floors acc. to cl. 1.2.1 of the ETA – the intumescent inlays which have to be arranged one behind the other have to be installed at the bottom side flushed within the separating element (without BIS Pacifyre® EFC Band)

Pipe dimensions (mm)		Insulation thickness (mm)	Intumescent inlay			Fire resistance classification
Outer diameter	Wall thickness		BIS Pacifyre® IM 3	BIS Pacifyre® IM 2	Nr. of layers	
≤ 28	1,0 to 14,2	6,0	X	X	2	EI 120-C/U E 120-C/U
≤ 28	1,0 to 14,2	6,0 to < 20,0	X	X	3	EI 120-C/U E 120-C/U
≤ 28	1,0 to 14,2	> 20,0 to 35,0	X	X	4	EI 120-C/U E 120-C/U

X ... valid intumescent inlay

**Pipe penetration seal
“BIS Pacifyre® EFC System”
- Fire resistance classification -**

ANNEX E-13

Metal pipes (copper pipes, steel pipes, stainless steel pipes) acc. to cl. 1.2.1 of the ETA, insulated with AF/Armaflex (length \geq 500 mm – on both sides of the separating element, continued-sustained CS) – in rigid floors acc. to cl. 1.2.1 of the ETA – the intumescent inlays which have to be arranged one behind the other have to be installed at the bottom side flushed within the separating element (without BIS Pacifyre® EFC Band)						
Pipe dimensions (mm)		Insulation thickness (mm)	Intumescent inlay			Fire resistance classification
Outer diameter	Wall thickness		BIS Pacifyre® IM 3	BIS Pacifyre® IM 2	Nr. of layers	
\leq 54	1,5 to 14,2	9,0	X	X	2	EI 120-C/U E 120-C/U
\leq 54	1,5 to 14,2	> 9,0 to 22,0	X	X	3	EI 120-C/U E 120-C/U
\leq 54	1,5 to 14,2	> 22,0 to 35,0	X	X	4	EI 120-C/U E 120-C/U
\leq 89	2,0 to 14,2	13,0	X	X	2	EI 120-C/U E 120-C/U
\leq 108	2,5 to 14,2	13,0	X	X	2	EI 120-C/U E 120-C/U

Metal pipes (only steel pipes and stainless steel pipes) acc. to cl. 1.2.1 of the ETA, insulated with AF/Armaflex (length \geq 500 mm – on both sides of the separating element, local-sustained LS or continued-sustained CS) – in rigid floors acc. to cl. 1.2.1 of the ETA – the intumescent inlays which have to be arranged one behind the other have to be installed at the bottom side flushed within the separating element (without BIS Pacifyre® EFC Band)						
Pipe dimensions (mm)		Insulation thickness (mm)	Intumescent inlay			Fire resistance classification
Outer diameter	Wall thickness		BIS Pacifyre® IM 3	BIS Pacifyre® IM 2	Nr. of layers	
\leq 108	2,0 to 14,2	13,0 to 30,0	X	X	2	EI 120-C/U E 120-C/U

Metal pipes (only steel pipes and stainless steel pipes) acc. to cl. 1.2.1 of the ETA, insulated with AF/Armaflex (length \geq 500 mm – on both sides of the separating element, local-sustained LS or continued-sustained CS) – in rigid floors acc. to cl. 1.2.1 of the ETA – the Pipe collar “BIS Pacifyre® EFC” has to be installed at the bottom side of the separating element						
Pipe dimensions (mm)		Insulation thickness (mm)	Intumescent inlay			Fire resistance classification
Outer diameter	Wall thickness		BIS Pacifyre® IM 3	BIS Pacifyre® IM 2	Nr. of layers	
\leq 108	2,0 to 14,2	13,0 to 30,0	X	X	2	EI 120-C/U E 120-C/U

X ... valid intumescent inlay

Pipe penetration seal “BIS Pacifyre® EFC System” - Fire resistance classification -	ANNEX E-14
--	-------------------